

SECTION 15

Wrg_0089B_01of08_104d_21101_std1

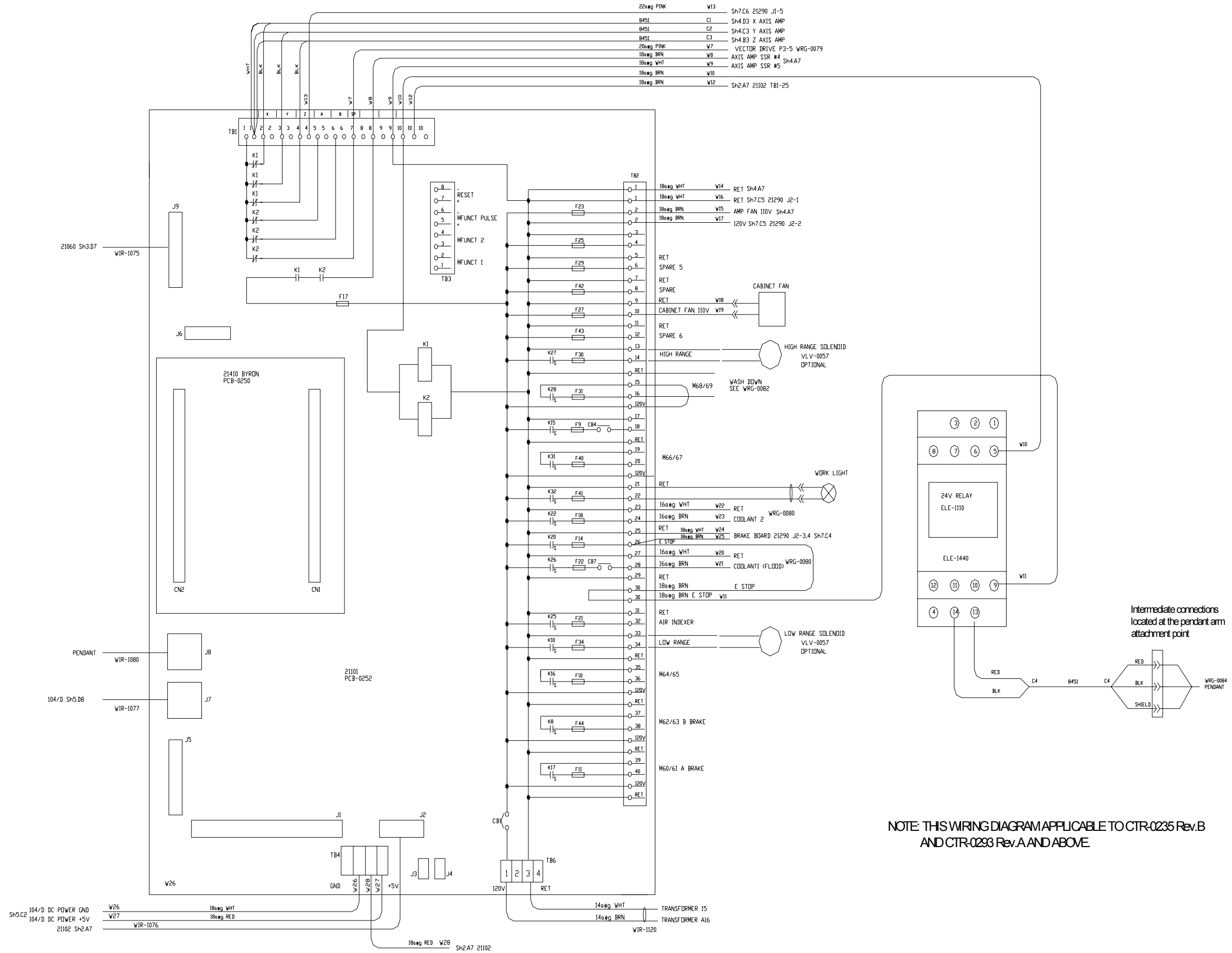

NOTE THIS WIRING DIAGRAM APPLICABLE TO CTR0235 Rev.B
AND CTR0293 Rev.A AND ABOVE

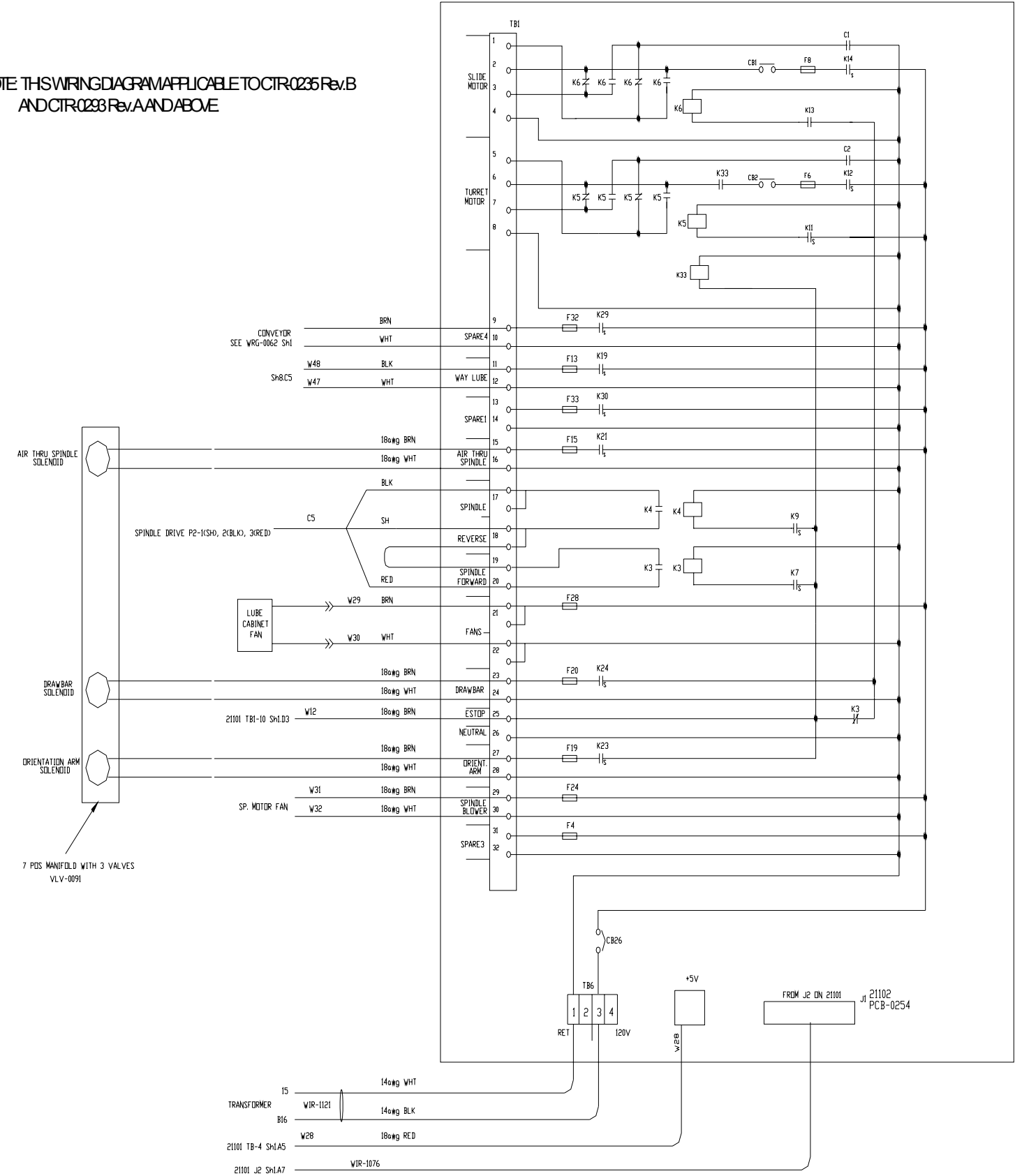

Wrg_0089B_03of08_104d_21060_std1

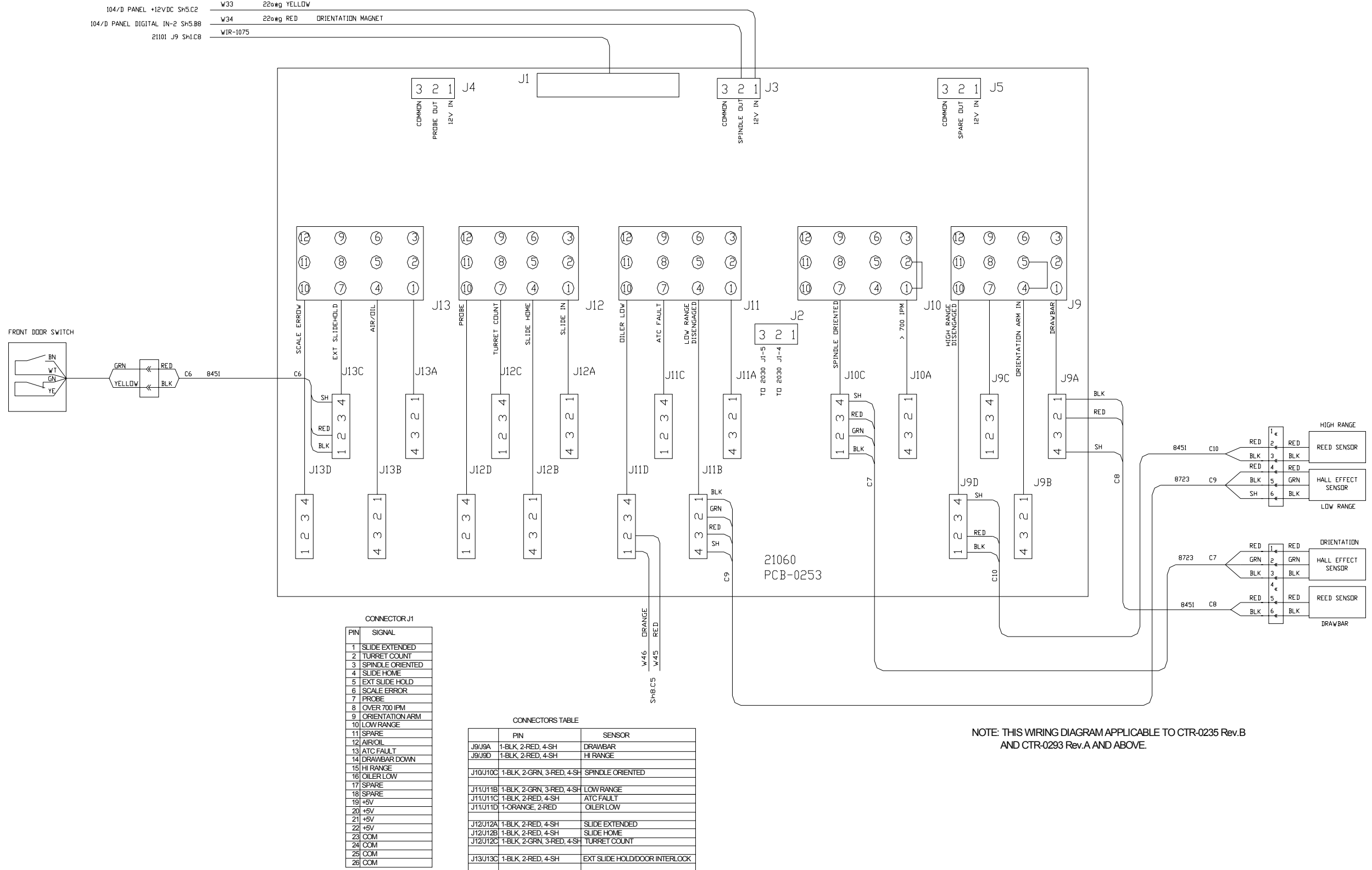

Wrg_0089B_04of08_104d_amp_std1

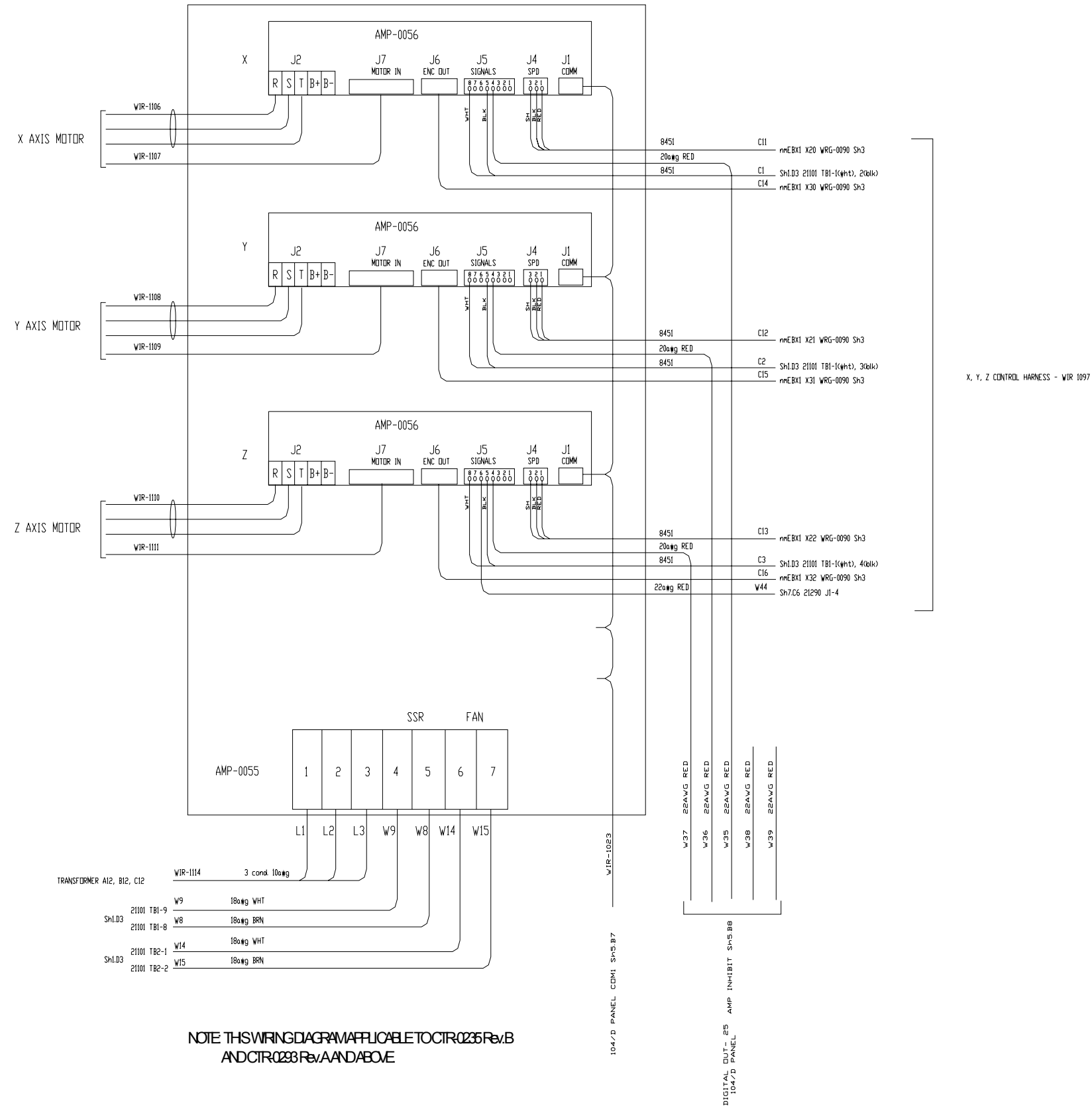

Wrg_0089B_05of08_104d_box_panel_std

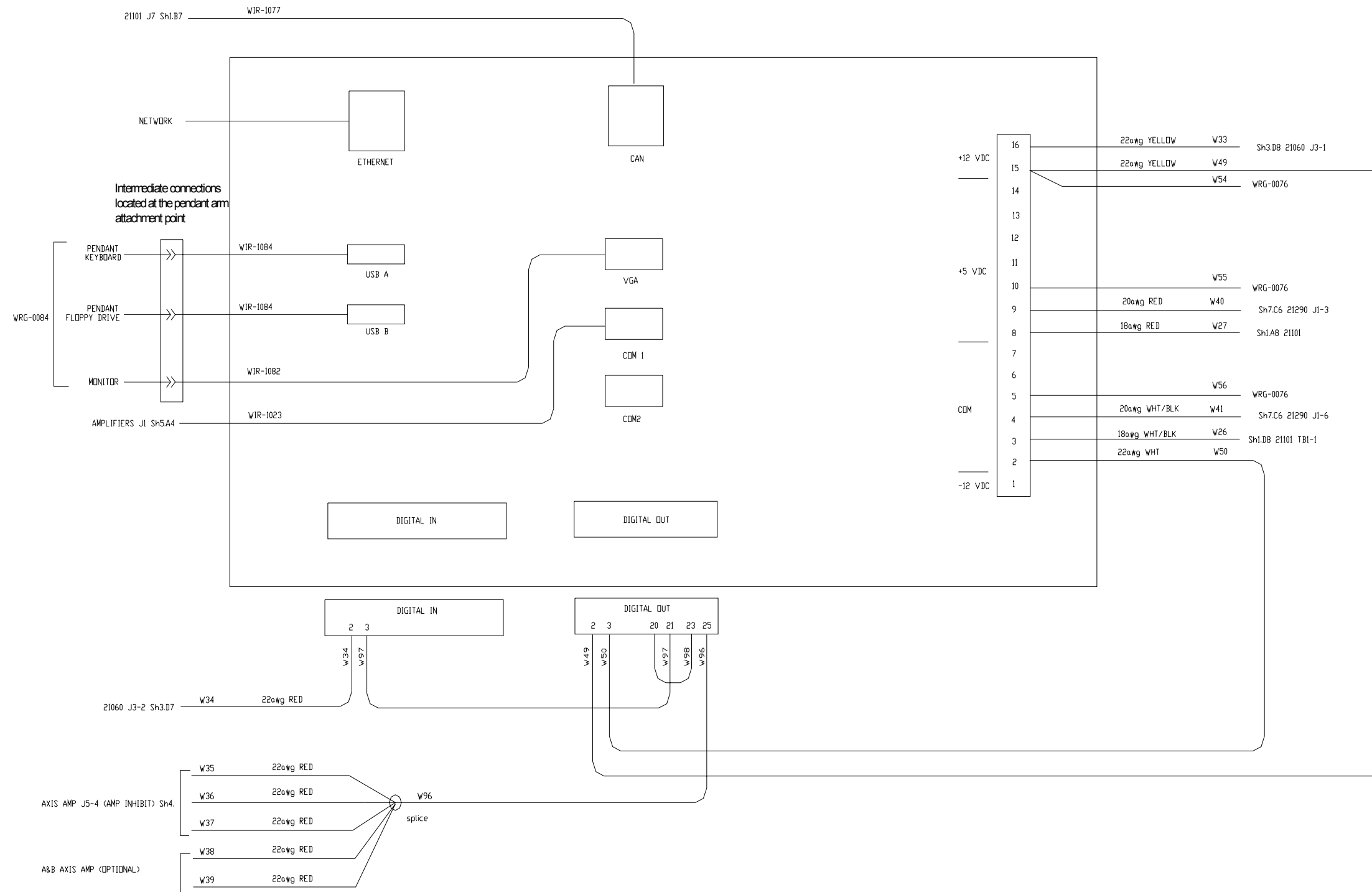

NOTE: THIS WIRING DIAGRAM APPLICABLE TO CTR-0235 Rev.B AND CTR-0293 Rev.A AND ABOVE.

DIGITAL OUT PLUG

PIN	DESCRIPTION
2	TO POWER CONNECTOR +12V
3	TO POWER CONNECTOR 0V
20	JUMPER TO 23, +12V
21	TO DIGITAL IN 3, 0V
25	TO AMP INHIBIT

DIGITAL IN PLUG

PIN	DESCRIPTION
2	TO 21060.J3-2 (ORIENTATION MAGNET)
3	TO DIGITAL OUT 21, 0V
4	FRICEE1
6	FRICEE2

Wrg_0089B_06of08_104d_24vdc_power_supply_std1

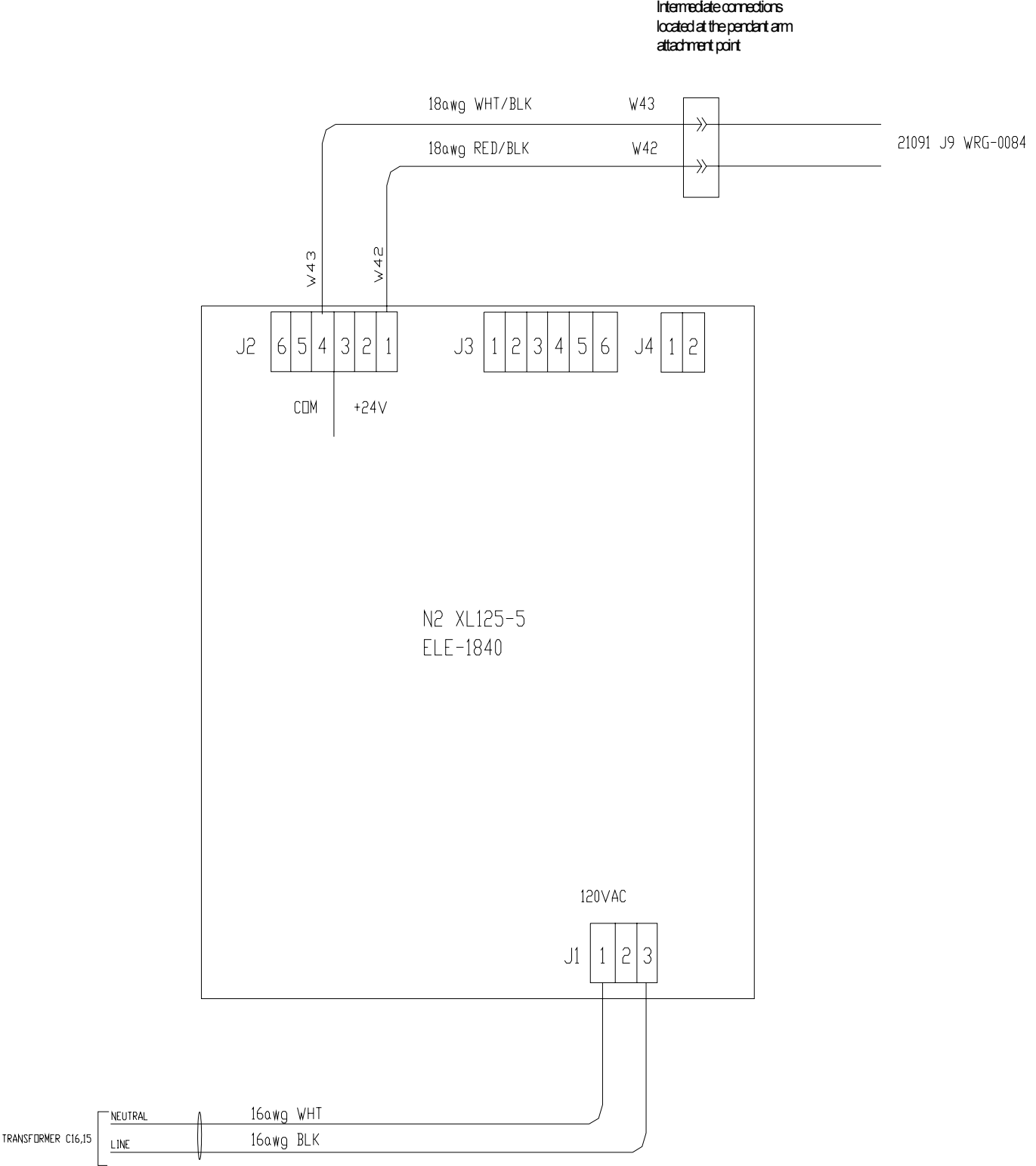

NOTE THIS WIRING DIAGRAM APPLICABLE TO CTR-0235 Rev.B AND CTR-0233 Rev.A AND ABOVE

Wrg_0089B_07of08_104d_21290_brake_board_std1

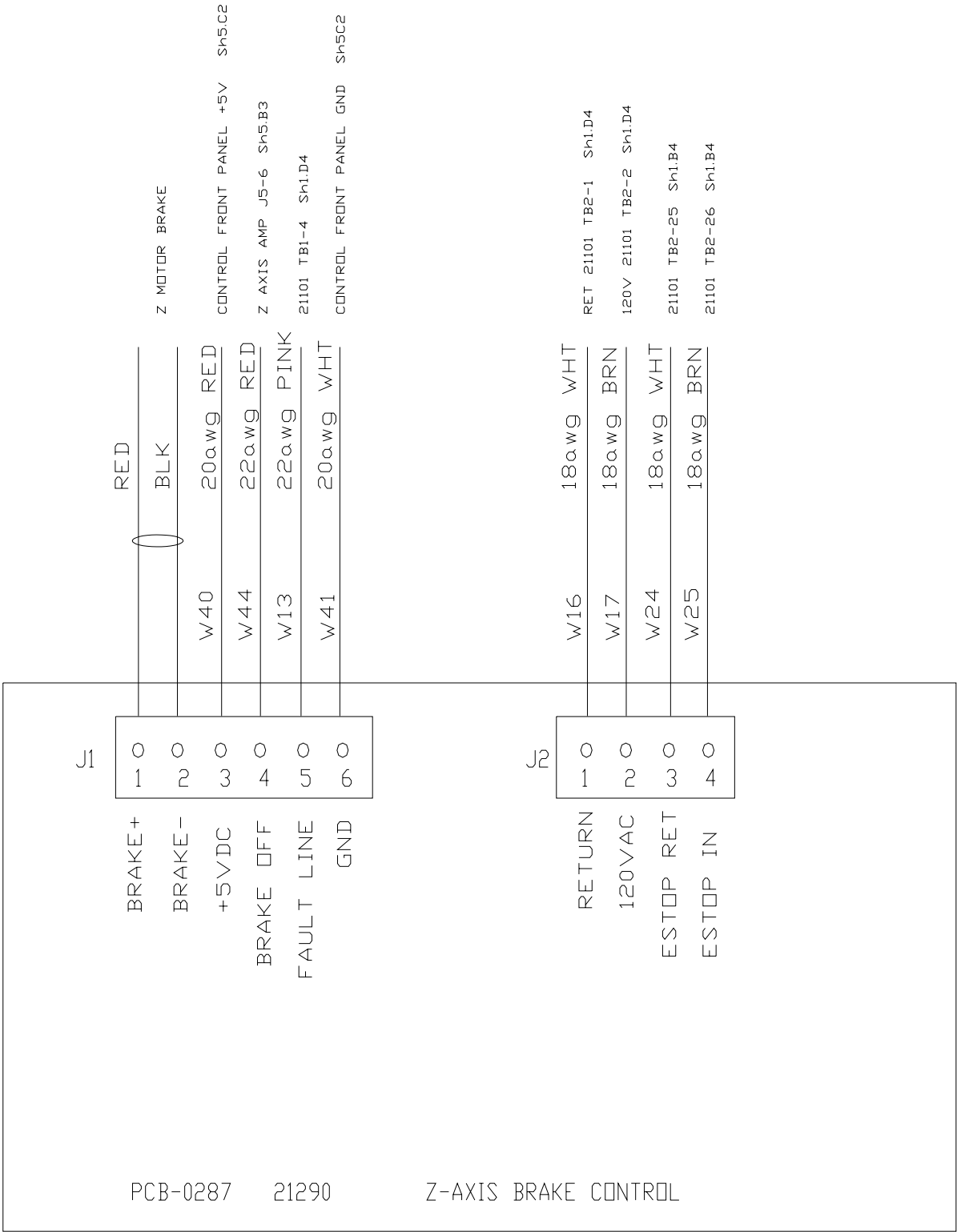

NOTE: THIS WIRING DIAGRAM APPLICABLE TO CTR-0235 Rev.B AND CTR-0293 Rev.A AND ABOVE

Wrg_0089B_08of08_104D_lube_pump_std1

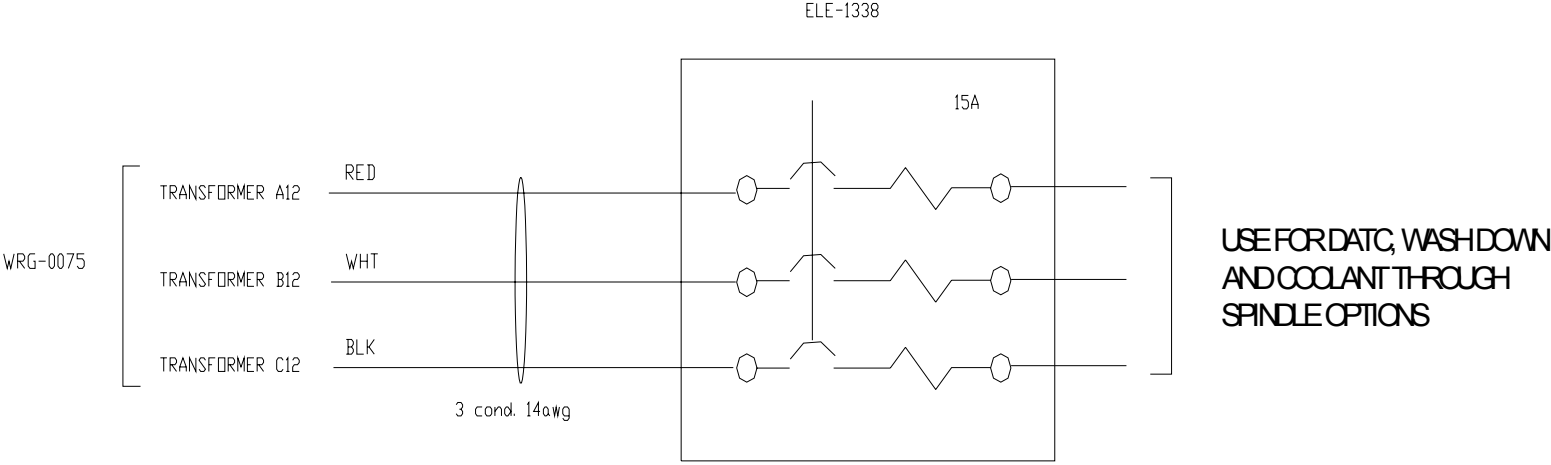
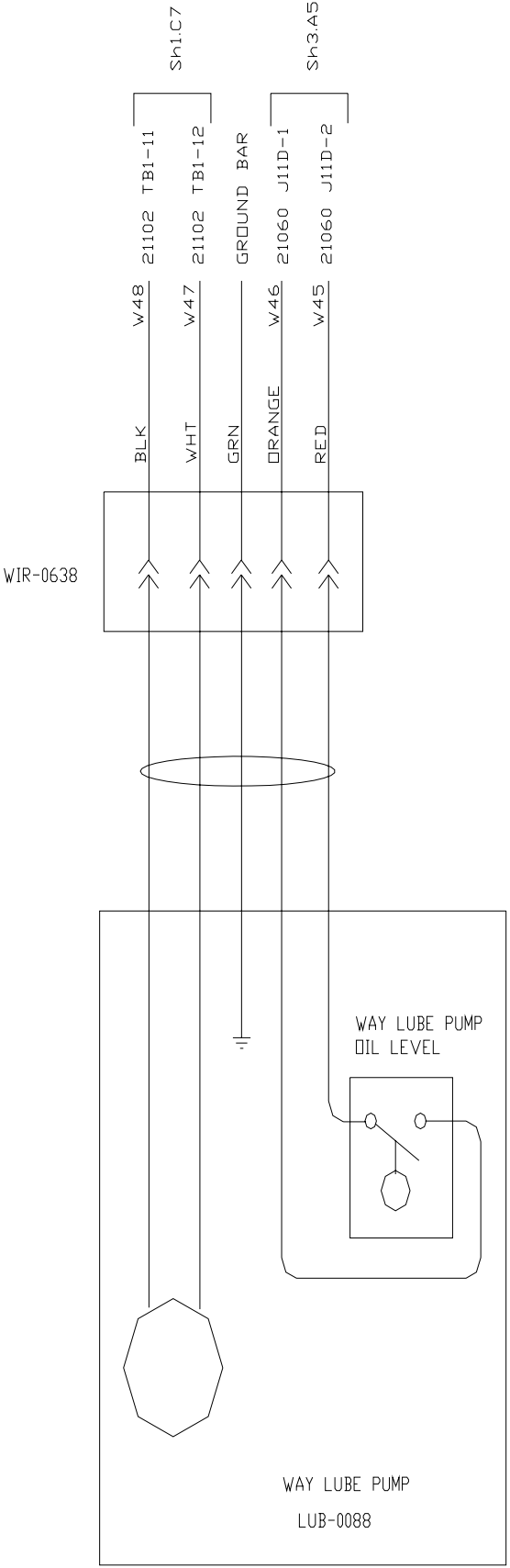

NOTE THIS WIRING DIAGRAM APPLICABLE TO CTR-0235 Rev.B AND CTR-0293 Rev.A AND ABOVE.

Wrg_0109_104d_ts27_probe

RENISHAW TS-27 PROBE

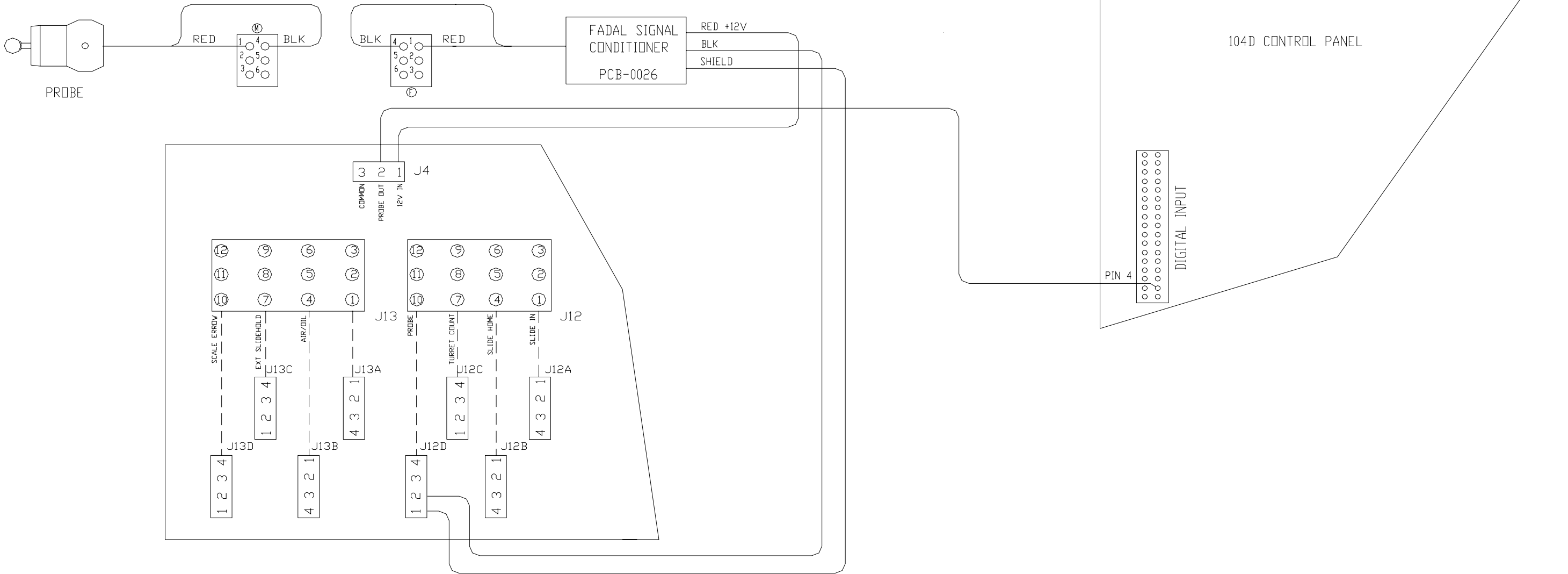
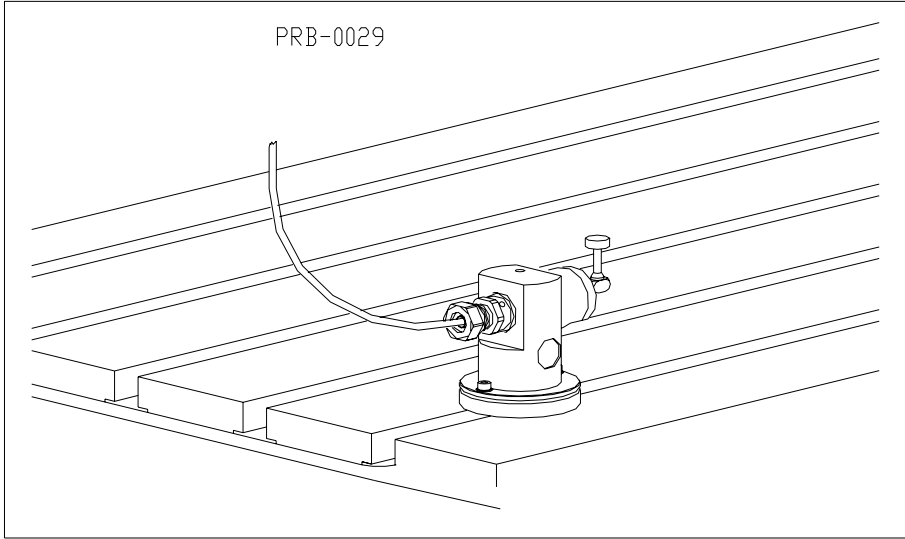

Wrg_0110_104d_mp12_omi

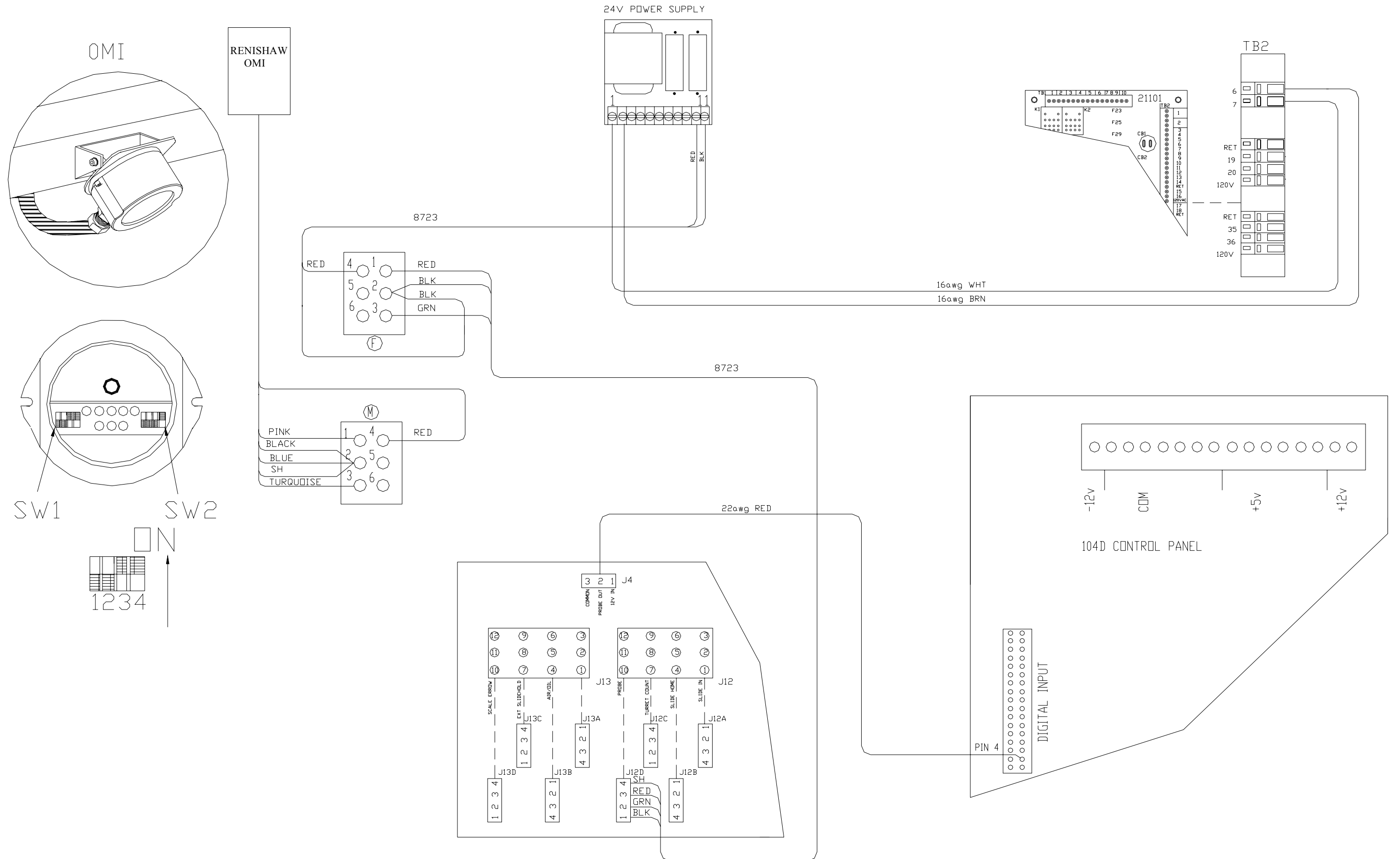

Wrg_0079B1_104D_spindle_drive

BALDOR SPINDLE DRIVE

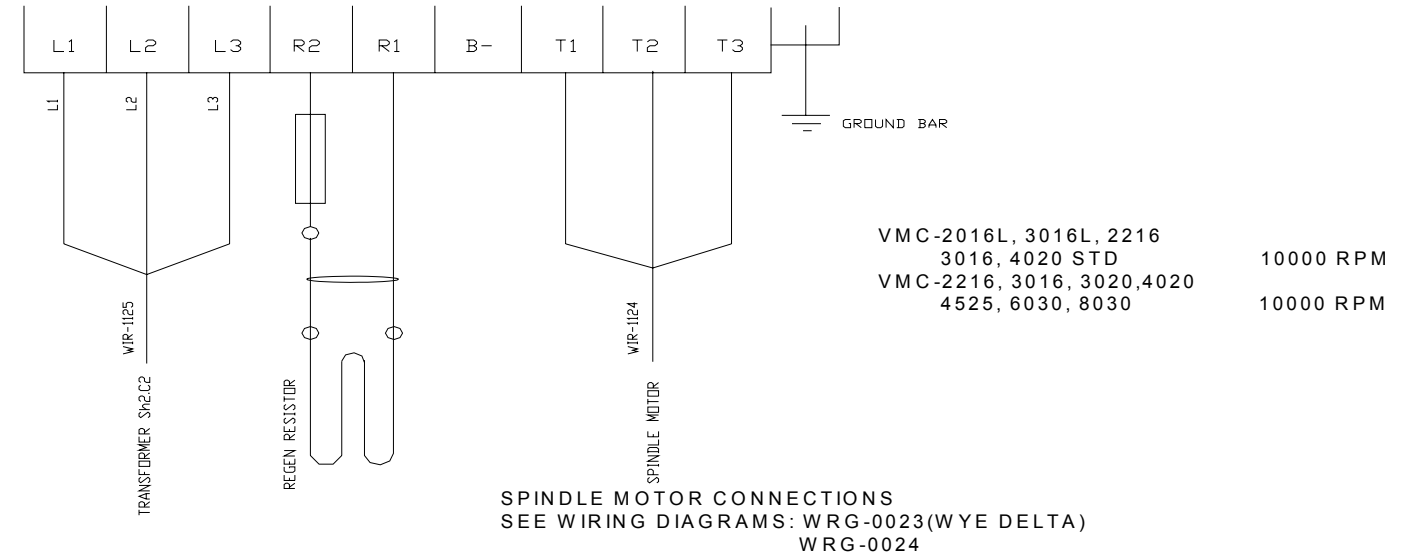
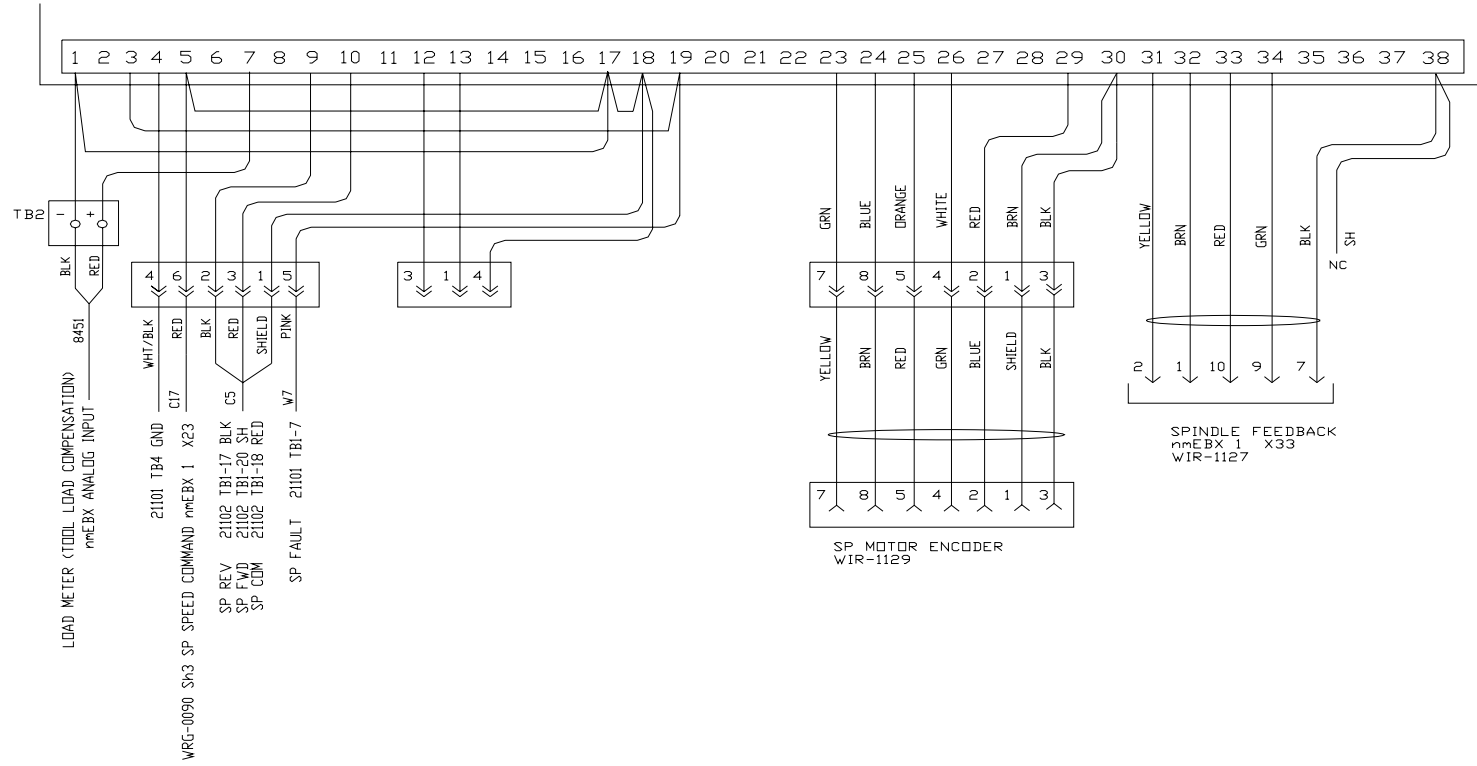

AMC SPINDLE DRIVE

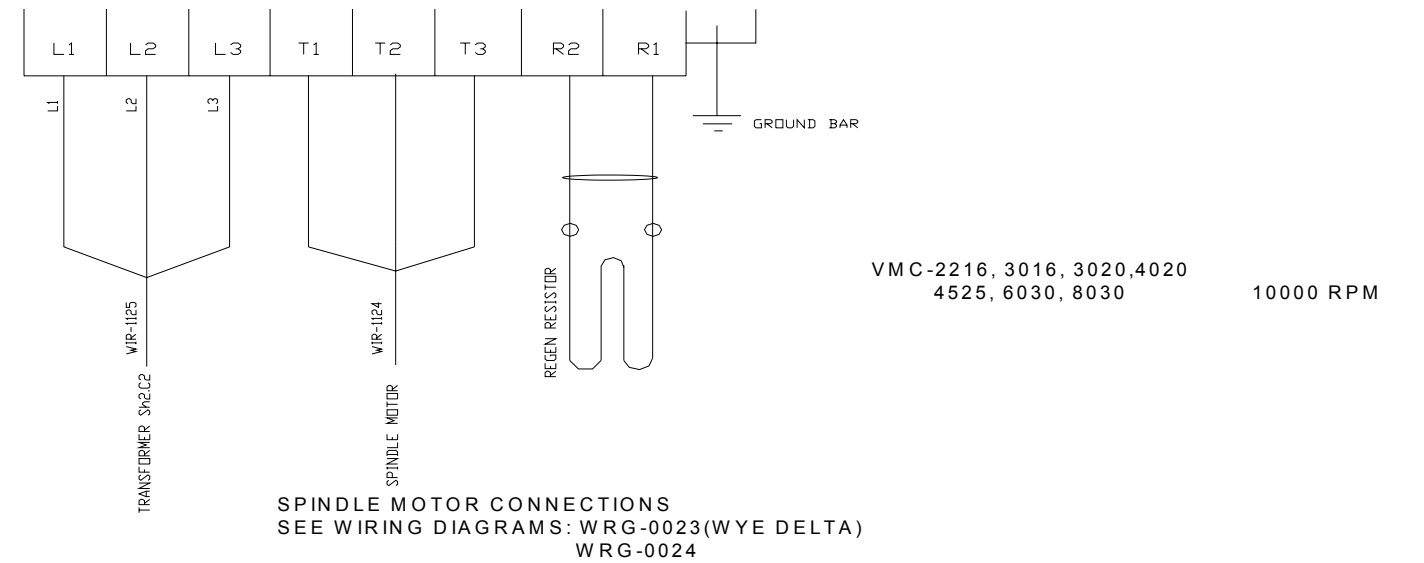
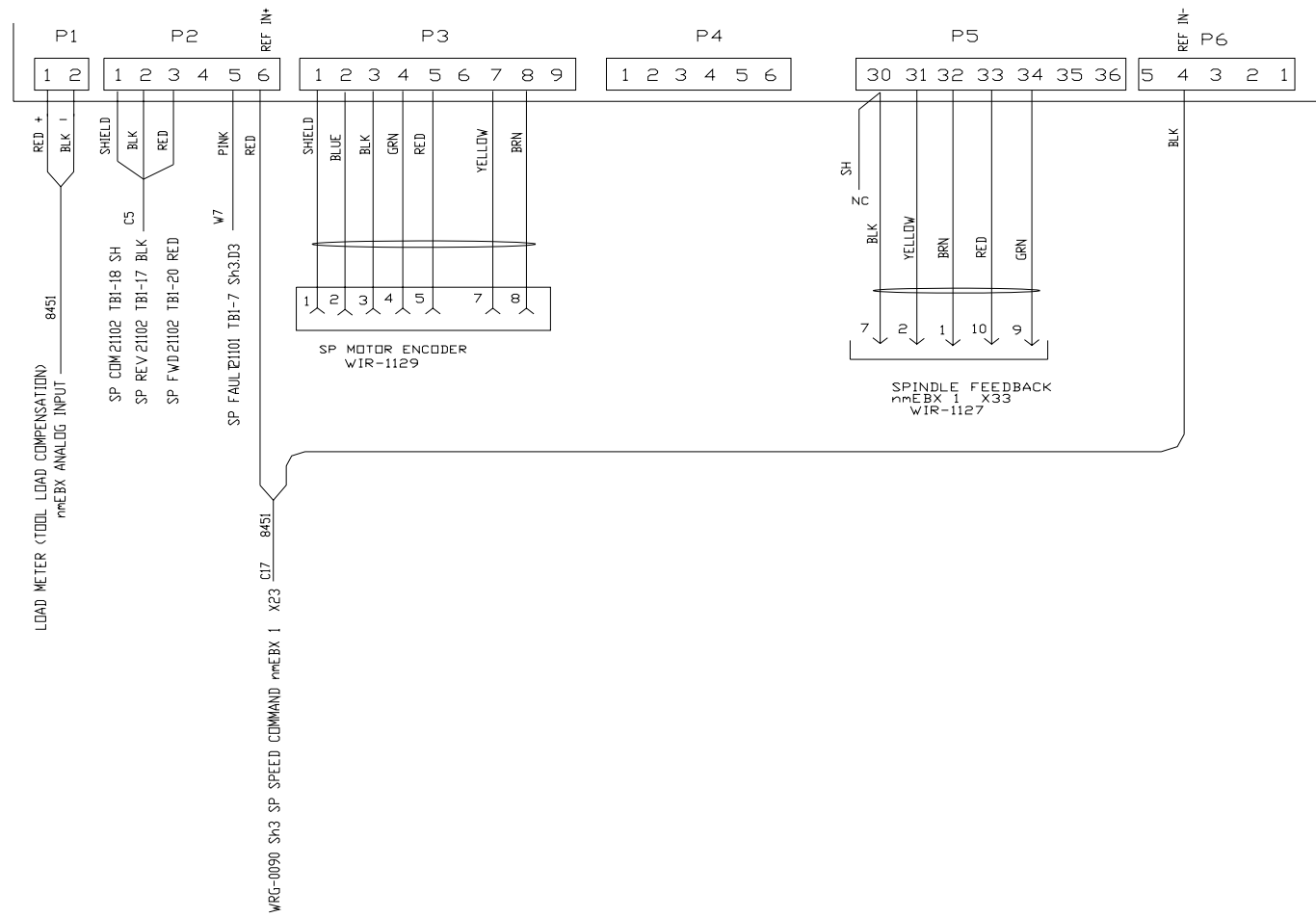

Wrg_0093A_104D_air_oil_1980

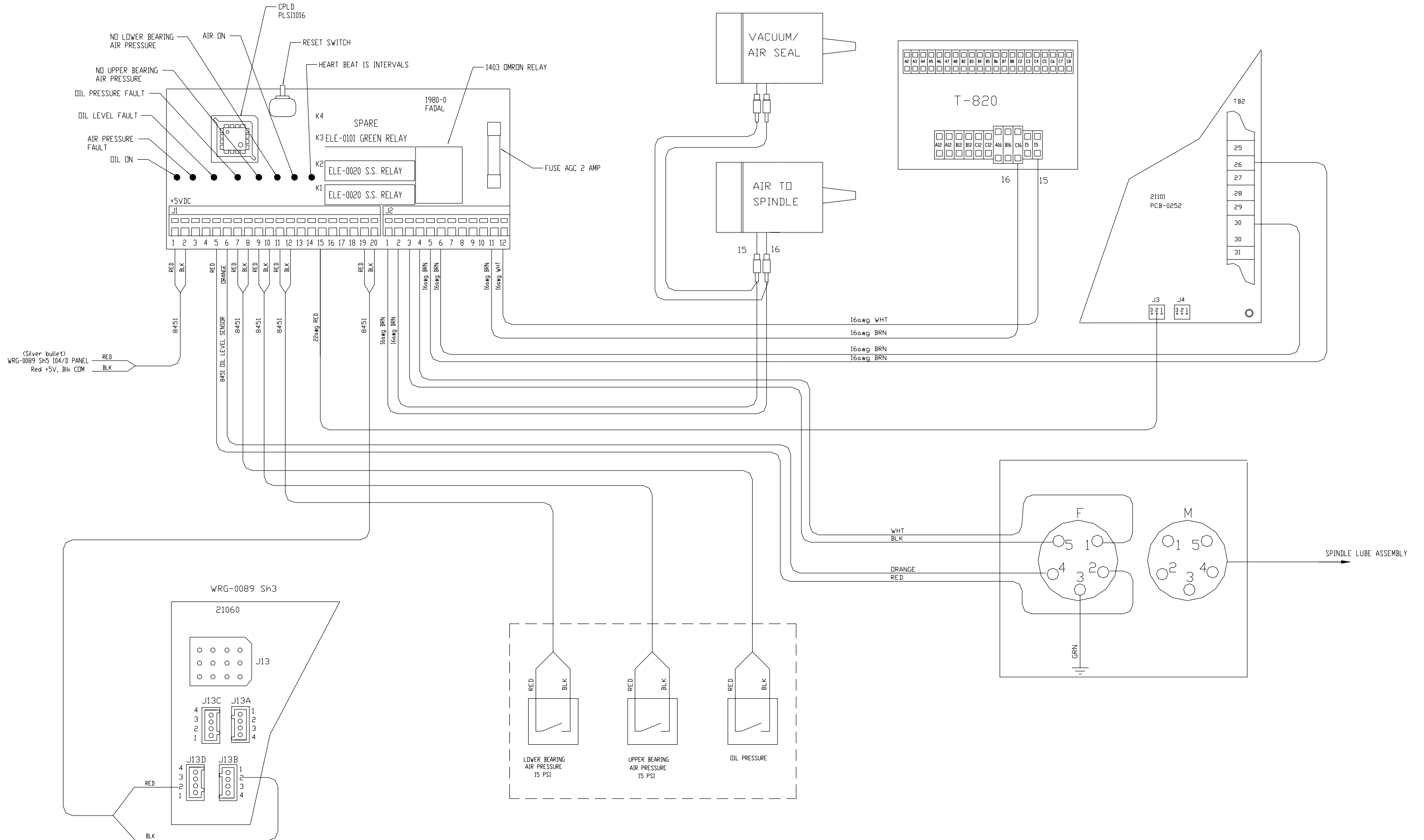

Wrg_0085A_104d_4axis

