Section 05: Automatic Tool Changers

Fadal's EMC model comes standard with a 16 tool capacity (21 tool capacity is optional) Geneva drive tool changer. The VMC 3020, 4525, 6535 come standard with the Dual Arm Tool Changer. The VMC TRM has no automatic tool changers. All other VMC models come standard with a 21 tool capacity (30 tool capacity optional) Geneva drive tool changer. An optional servo drive tool changer is available with 21 or 30 tool capacity.

Operation

Programming

To make an automatic tool change, an *M6* code is used. This code can be used in a program or in Manual Data Input (MDI) mode.

In a Program

When another tool is needed, an *M6* followed by a tool location. (*T_*) is entered and the tool changer will make the appropriate tool change and then continue on with the program.

In MDI

The operator can make a tool change with out running a program. If the operator is testing the tool changer or setting tool lengths, the *M6* code followed by the tool location will command the tool changer to make the necessary tool change.

Electrical Operation

The ATC has two circuits; one is for the Turret (changes tool positions) and the other is for the Slide (moves ATC to the spindle and back) motor circuit. Both of these circuits are basically the same with the only differences being the motor gear ratios (Turret motor is 28:1 and Slide motor 58:1) and the K33 contacts in the turret circuit. This description will be for both circuits, with parts from the turret and slide parts in parentheses (). Negative logic is used meaning that to pull a line low or to about ground (Gnd) is considered on or active. The output leads on the solid state relays will be referred to as contacts for ease of explanation. The word "direction" used in this section refers to motor direction not machine direction.

The Turret Motor (Slide Motor) is activated when the Mill Interface PCBA (1040) pulls the line low (to Gnd), pin 16 (57), which goes through the following connections:

1060/J7-25 (1060/J7-24)
to 1100-1/J1-25 (1100-1/J1-24)
to 1100-1/J2-5 (1100-1/J2-14)
to 1100-2/J1-5 (1100-2/J1-14)

to Solid State Relay K12 (K14) on one side of the control with the other side connected to 5 VDC. This activates the relay, closing the contacts (output leads) and allowing the 120VAC to flow to F6 (F8), CB2 (CB1) and to the contacts of mechanical relay K5 (K6) and from TB1-6 (TB1-2) to the motor windings. The other side of the motor windings is connected to TB1-8 (TB1-4) and to the RET (AC Return). This provides the power to the motor windings.

The 120 VAC power for the start winding flows to the 3 & 4 pins of K5 (K6) to TB1-7 (TB1-3) to the Start winding with the other side of the Start winding connecting to TB1-5 (TB1-1) to pins 9 & 10 of K5 (K6) and then to C2 (C1). This causes a phase shift in the Start winding current and the motor starts in the forward direction caused by the phase shift.

When reverse direction is required both the reverse and motor signal have to be activated. The turret (slide) motor reverse is activated when the Mill Interface PCBA (1040) pulls the line low on pin 5 (9) which goes through the following connections:

1060/J7-6 (1060/J7-1)
to 1100-1/J1-6 (1100-1/J1-1)
to 1100-1/J2-12 (1100-1/J2-1)
to 1100-2/J1-12 (1100-1/J1-1)

to Solid State Relay K11 (K13) on one side of the primary with the other side connected to 5 VDC. This activates the relay, closing the contacts and allows the 120 VAC to flow to F5 (F7), to the coil of the Mechanical Relay K5 (K6), opening the normally closed contacts and closing the normally open contacts.

The power to the motor windings is the same as for the forward direction. The power to the start windings now flows to pins 5 & 6 of K-5 (K6), to TB1-5 (TB1-1), to the Start winding, returning to TB1-7 (TB1-3), to pins 11 & 12 of K5 (K6), and to C2 (C1). This causes the phase shift to be in the other direction. The motor runs in reverse.

The motor braking for this turret motor is provided by the gear box and the gear box grease for the Bodine brand motors and by a wavy washer for the Bison brand motors. If the grease breaks down the turret will overshoot. Repack grease in gear box to resolve.

The K33 contacts are controlled by the E-Stop circuit on the coil side of the relay. The contacts will open when an E-Stop condition exists and will stop the operation of the turret.

The K3 relay has two sets of normally closed contacts (3,4 to 11,12), which provide a path for the 120 VAC for the drawbar and slide motor reverse circuits. This performs two functions: One is the removal of power during an E-Stop condition and the other is the removal of power when the spindle is running in the forward direction.

Tool Change Sequence

The following is the order of operations for the CNC when making a tool change (Geneva driven and Servo Turret):

- 1) Move the Z axis to the machine home (cold start) position.
- 2) Turn the spindle slowly while looking for the Orientation Sensor signal.
- 3) When orientation signal is received, stop the spindle.
- 4) Activate the orientation arm.
- 5) Move the ATC turret to the tool position of the tool in the spindle.
- 6) Verify the orientation sensor.
- 7) Check the ATC Home sensor and verify that the ATC is at the home position.
- 8) Activate the ATC slide reverse circuit.
- 9) Activate the ATC slide motor circuit (air cylinder circuit for the EMC).
- 10) Watch for the ATC extended sensor signal.
- 11) Stop the slide motor (air cylinder for the EMC) when the extended position sensor is read.
- 12) Activate the draw bar.
- 13) Watch for the drawbar sensor detection (air feed parameter).
- 14) Check for the ATC fault switch.
- 15) Move the Z axis up to 3.8" above the cold start position.

- 16) Activate the turret motor and the turret reverse (if the reverse direction is required) circuit(s).
- 17) Count the turret sensor signals, with a dwell time for coasting as set by the turret factor, until the requested tool position is reached.
- 18) Stop the turret motor.
- 19) Move the Z axis downward to the machine home position.
- 20) Check for the ATC fault switch.
- 21) Release the drawbar circuit.
- 22) Activate the ATC slide motor.
- 23) Watch for the ATC Home sensor, to determine the ATC home position.
- 24) Stop the ATC slide motor (air cylinder for the EMC).
- 25) Release the orientation arm.

Note: The hall effect sensors have three wires. One for 5vdc, one for ground, and one for the signal. The signal will be about 5vdc until a magnet is over it, then it will become active, and the signal will be about zero.

ATC Sensors & Switch

The ATC Slide Home sensor is active when the ATC is in the home position. The connections are 1060/J12 pin 4 for Gnd, pin 6 for 5 VDC, pin 5 for the signal connecting to the 1040 PCBA at pin 72.

The ATC Slide Extended sensor is active when the ATC is at the extended position under the spindle. The connections are 1060/J12 pin 1 for Gnd, pin 3 for 5 VDC, pin 2 for the signal connecting to the 1040 PCBA at pin 70.

The ATC Turret Motion sensor is active when the turret is moving to the next tool position and it is half way to the next tool position. The connections are 1060/J12 pin 7 for Gnd, pin 9 for 5 VDC, pin 8 for the signal connecting to the 1040 PCBA at pin 74.

The ATC Fault switch is closed if the ATC spindle is moved out of position. The connections are 1060/J11 pin 7 for Gnd and pin 8 is the signal to the 1040 PCBA at pin 66.

ATC Fault Messages

ATC FAILURE: The machine is receiving a signal from the ATC fault switch. This would indicate that the ATC spindle is out of position. Check the position of the ATC spindle. If it is in the proper position, check the switch, the switch wiring, and the mill interface card.

ATC TURRET FAILURE: The machine did not receive a signal from the ATC Turret Sensor, when the tool position change was commanded. If the turret moved to the next position, then the sensor is not operating. This could be caused by a bad sensor, wiring problem, Mill Interface (1040), sensor to magnet spacing, or chips on the sensor or magnet. If the turret does not move, then the turret motor circuit is not operating. This may be caused by a mechanical bind, K12, F6, CB2, K33, turret motor, wiring problem or mill interface (1040).

ATC WILL NOT MOVE TO POSITION: When the ATC is commanded to move to either the extended or home positions and the appropriate sensor does not send a signal within the allotted time, this fault is displayed. The possible causes for this fault are mechanical problems including chips in the track area preventing the rollers from rolling, misalignment of the ATC or spindle position, bad sensor or gap setting, wiring problem, motor, or the mill interface board (1040).

ATC WILL NOT MOVE TO SPINDLE: Same as the ATC WILL NOT MOVE INTO POSITION except the direction (reverse) is known.

ATC Servo Turret Operation

The turret Motor is activated when the Mill Interface PCBA (1040) pulls the line low (to Gnd) pin 16 which goes though the following connections:

1060/J7-25
to 1100-1/J1-25
to 1100-1/J2-5
to 1100-2/J1-5

to Solid State Relay K12 on one side of the control with the other side connected to 5 VDC. This activates the relay, closing the contacts (output leads) and allowing the 120 VAC to flow to F6 to CB2 to the contacts of mechanical relay K33 and to 1100-2/TB1 pins 6 (black wire), which is connected to the Servo Turret Control board (1860) at J3-1. This signal tells the Servo Turret Control board to turn turret motor on. Pin 8 (white wire) the RET (AC Return) is connected to the Servo Turret Control board (1860) at J3-4.

The Turret start motor connection at 1100-2/TB1 pin 7 is connected to the Servo Turret Control board at J3-2 (red wire) and pin 5 is not connected. A wire is added from the 1100-2/TB1-31 (120 VAC) to Control board J3-3 (blue wire). The servo turret requires that jumper be placed across CB7, a AGC2 fuse be added to F4, K12 Black relay be replaced with a Green relay (ELE-0101). Also the inside lead (connects to K5) of C2 be moved to the outside connection (return side) on the 1100-2 PCBA to remove the capacitor from the circuit, if this is not done the control may never get the off signal and turret would continue to run.

When reverse direction is required both the reverse and motor signal have to be activated. The turret motor reverse is activated by the Mill Interface PCBA (1040) pulls the line low on pin 5 which goes through the following connections:
1060/J7-6
to 1100-1/J1-6
to 1100-1/J2-12
to 1100-2/J1-12

to Solid State Relay K11 on one side of the primary with the other side connected to 5 VDC. This activates the relay, closing the contacts and allows the 120 VAC to flow to F5 to the coil of Mechanical Relay K5 opening the normally closed contacts and closing the normally open contacts. Resulting in 1100-2 TB1-7 to 1860 J3-2 line having 120VAC for forward and 0 VAC for reverse when the motor line is active.

For the Turret Motion sensor, the Hall effect switch for ATC turret connects to J6 on the Servo turret control board (1860). Pin 1 is 5 VDC, pin 2 is the signal and pin 3 is Gnd. The sensor connections from the motherboard (1060) J12 connect to the control board at J5, signal connecting J12-8 to J5-4, Gnd J12-7 to J5-3 and J12-9 5 VDC not connected.

For an AC Brushless machine, a Power Supply (PCB-0173) is required because the DC motor amp chassis outputs about 130 VDC on the axis amplifier chassis capacitor and the AC motor chassis outputs about 320 VDC. The servo turret amplifier does not operate correctly with the excess voltage. If the machine requires a power supply, then the wiring connections are pins 1 & 2 on the power supply. Connect to TB1-9 & TB1-8 respectively on the 1100-1 board, which is the control signal input. Pins 3 & 4 on the power supply connect to the 120 RET and VAC terminals on the 1100-2 PCBA. Pin 5 on the power supply connects to pin 3 on J2 (black wire) of the servo turret amp PCBA (1810). Pin 6 on the power supply connects to pin 4 on J2 (red wire) on servo turret amp. This is the amp's power.

K33 contacts are controlled by the E-Stop circuit on the coil side of the relay. Contacts will open when E-Stop condition exists and stop operation of the turret.

K3 has two sets of normally closed contacts (3,4 to 11,12) which provide a path for the 120 VAC for the drawbar and slide motor reverse circuits. This performs two functions: One is the removal of power during the E-Stop condition and the other is removal of power when the spindle is running in the forward direction.

Servo Turret Controller and Amplifier Boards (PCB-0108)

The Servo Turret Amplifier Assembly (PCB-0108) consists of a mounting plate, Controller board 1860 and a Amplifier board 1810.

The Amplifier board has an input of about 130VDC and the motor output at J2. Two motor circuit fuses are AGC10A. J1 and J3 provide communication between the Amplifier and the Controller boards. The Amp also has an LED to indicate over temperature and for over current.

The Controller board has J1 and J4 for communication between the boards. The controller receives feedback (1860/J2) from an encoder on the motor with a 1:1 ratio to worm gear and three revolutions for one tool position change. The encoder is a 1000 line per revolution encoder. J3 is the input connection for the command signal from the 1100-2 board. 5 VDC and ground are provided on pins 1 and 2 of J5 and output the Turret Motion signal to the Motherboard (1060/J12 pins 7 & 8) from pins 3 and 4. The Turret Motion Hall Effect Sensor is connected to J6. The Controller has an LED for the Turret Motion sensor active and a pulse LED flashes indicating the board is active. S1 is a reset switch for the board.

The only adjustments on the Servo Turret board are by means of the four dip switches.

SPEED	SW1	SW2	MOTOR RPM
Slow	0 Closed	0 Closed	550
Medslow	1 Open	0 Closed	600
Medfast	0 Closed	1 Open	650
*Fast	1 open	1 open	750

MOTOR	SW3	SW4
Reserved	0 Closed	0 Closed
Reserved	1 Open	0 Closed
Reserved	0 Closed	1 Open
*Owisso/Bodine	1 Open	1 Open

*Factory Setting

Random servo amp faults may occur, often with either heavy tools and/or the 30 tool ATC. Lowering the motor speed selection has been successful at eliminating these servo amp faults. However, this is not recommended because of the possibility of the Z axis coming down prior to the ATC turret reaching its position.

Adjustments

There are four motions that influence the automatic tool changer alignment. These motions are:

- Z-axis up & down.
- Spindle orientation.
- Turret in & out.
- Turret rotation.

Z Axis Cold Start Adjustment

- 1) Remove the ATC upper cover.

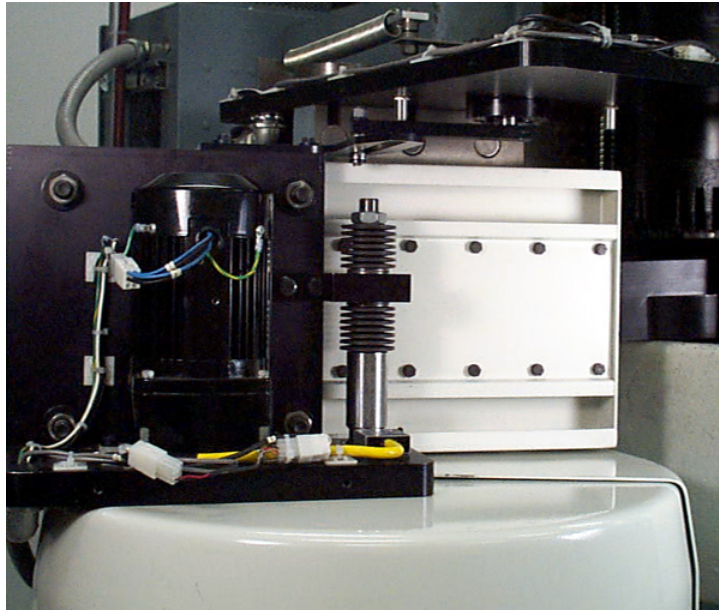

Figure 5-1 Remove ATC Upper Cover

- 2) Position the Z-axis head to the machine zero position (CS).
- 3) Orientate Spindle (M19).
- 4) Manually move the ATC slide in toward the spindle

Note: The EMC machine uses an air cylinder for the turret movement. To manually move the ATC as suggested in step (4) several steps must be taken:

- Disconnect the air to the machine.
- Manually move the ATC slide towards the spindle.
- Re-connect the air to the machine for added pressure against the spindle.

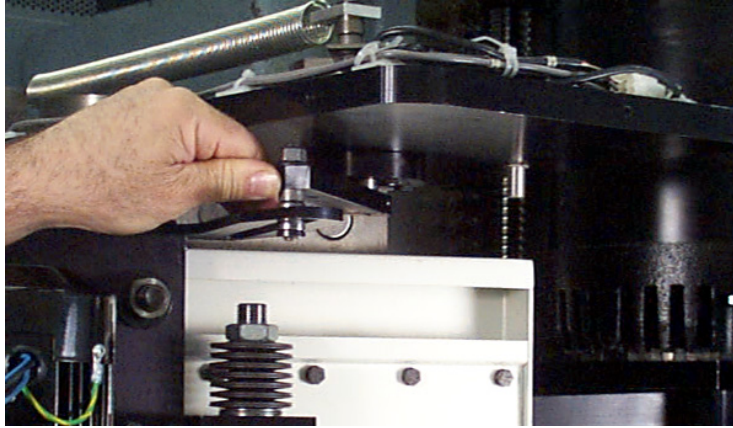

Figure 5-2 Move ATC Slide Toward Spindle

- 5) Measure the distance from the ATC carriage to the nose of the spindle with a thickness gauge. Adjust the Z axis until the nose of the spindle is .050" [1.27mm] above the turret carriage for CAT taper, .250" [6.35mm] for BT tooling.

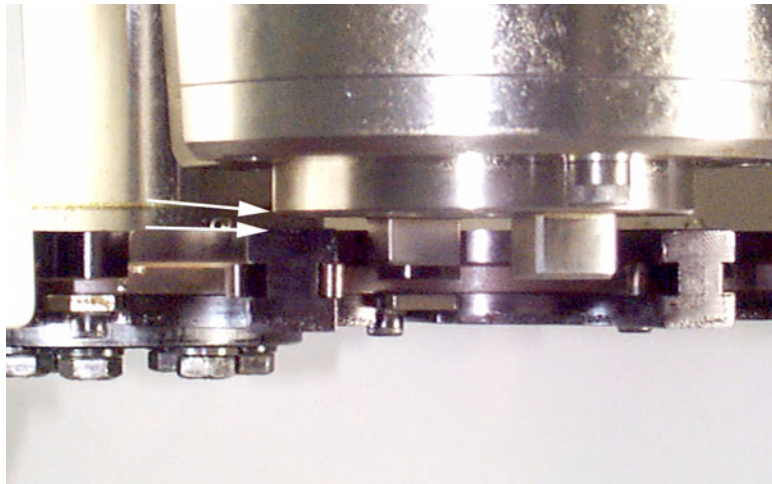
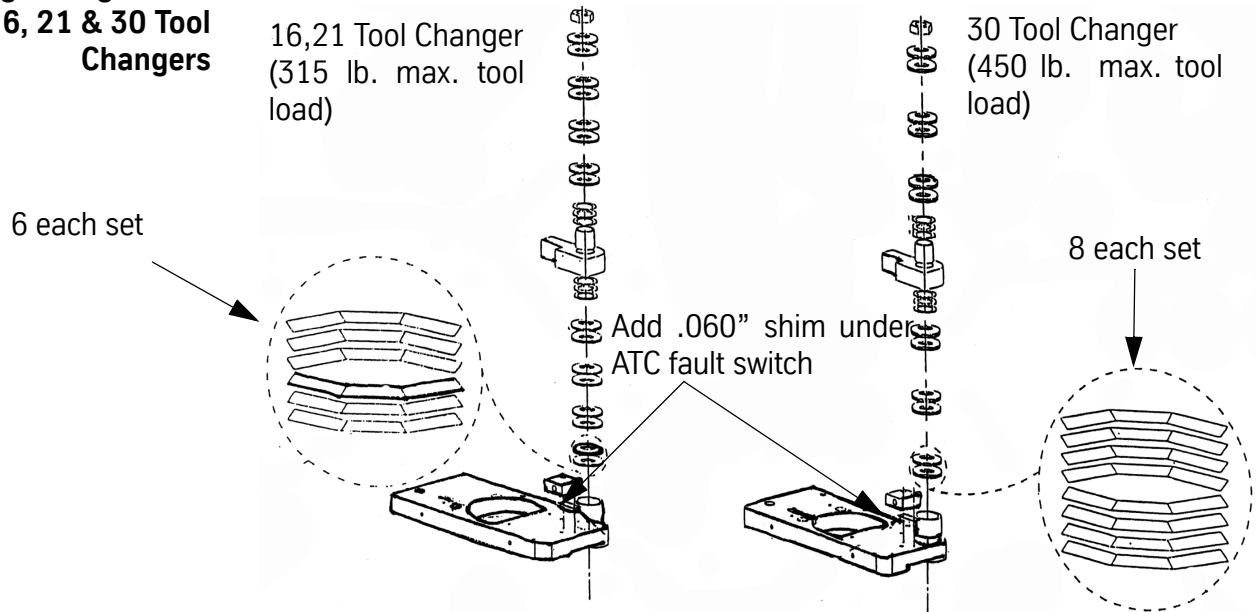

Figure 5-3 Measure Distance from ATC Carriage to Spindle

- 6) To adjust DC machines, loosen the screw holding the resolver and rotate the resolver. When the Z axis is in the correct position, tighten the screws. For AC machines, determine their offset by cold starting the machine then jogging the Z axis. Enter the value in SV.
- 7) Cold Start the machine and recheck the position.

Spring Configuration 16, 21 & 30 Tool Changers



ATC Turret Slide Adjustment

- 1) Position the Z-axis to the machine zero.
- 2) Orient the spindle using M19 from MDI mode.
- 3) Insert a tool holder in the spindle.
- 4) Manually move the slide to the spindle until fully engaged. Loosen the 2 each 1/4" hex bolts to the upper Geneva slot

Note: The EMC machine uses an air cylinder for the turret movement. To manually move the ATC as suggested in step (4) several steps must be taken:

- Disconnect the air to the machine.
- Switch the air lines connected to the air cylinder (see figure 5-5)
- Manually move the ATC slide towards the spindle.
- Re-connect the air to the machine for added pressure against the spindle.

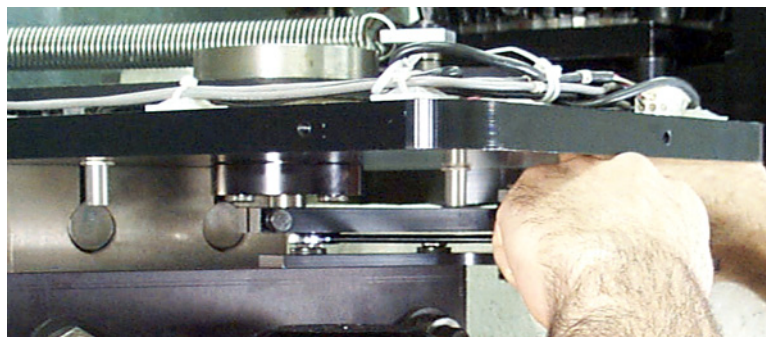

Figure 5-4 Move Slide to Spindle Until Engaged

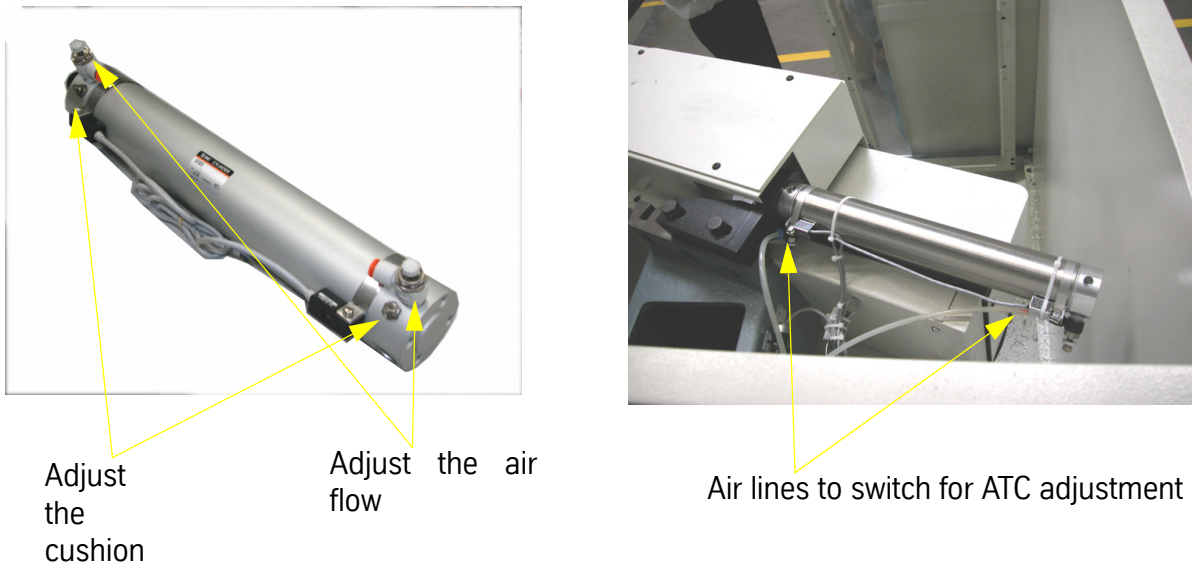

Figure 5-5 EMC ATC Cylinder

- 5) Give the slide a firm push toward the spindle. Retighten the 2 bolts.
- 6) If the slide does not fully engage, loosen each of the six 3/8" hex bolts holding the tool carrier. This will allow the slide to fully engage.



Figure 5-6 Loosen Hex Bolts Holding Tool Carrier

- 7) Tighten all bolts on tool carrier and upper Geneva slot. If the slide still does not engage, check the spindle orientation.

Note: continue with step (8) through (12) only if your machine is an EMC model VMC. (see Figure 5-5)

- 8) Disconnect the air to the machine.
- 9) Move the ATC slide back.
- 10) Switch the air lines connected to the air cylinder.
- 11) Re-connect the air to the machine.

12) Adjust the air flow. Make sure that the ATC doesn't move too quickly or too slowly on a tool change.

13) Adjust the cushion. Make sure that during the tool change the ATC doesn't "bang" at either end of its travel.

Tool Turret Rotational Adjustment

1) Position the Z-axis to the machine zero.

2) Orient the spindle using M19 from MDI mode.

IMPORTANT

For Servo Turret, do not adjust the rotation until the turret has been moved by pressing TURRET CW, and then pressing TURRET CCW.

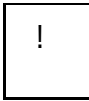

3) Loosen each of the six 3/8" hex bolts on the under side of the tool carrier.



Figure 5-7 Loosen Hex Bolts on Under Side of Tool Carrier

4) With the tool in the spindle, manually move the slide into the spindle, until fully engaged.

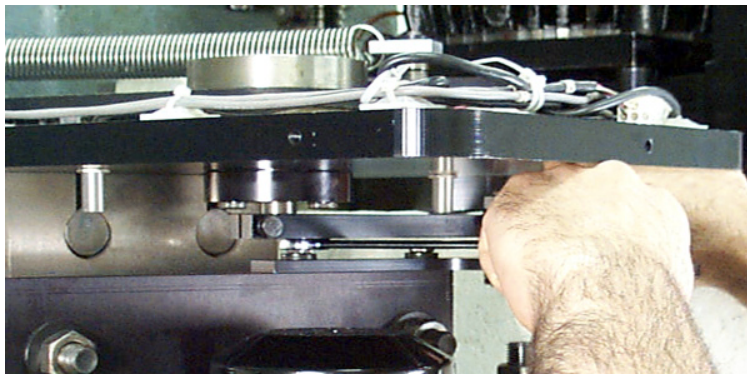

Figure 5-8 Manually Move Slide Into Spindle

5) Tighten the 6 each 3/8" hex bolts.

If the tool carrier does not engage smoothly with the tool in the spindle there may be a misalignment with orientation assembly.

**ATC Slide Belt
Replacement &
Adjustment**

- 1) Remove ATC upper cover.

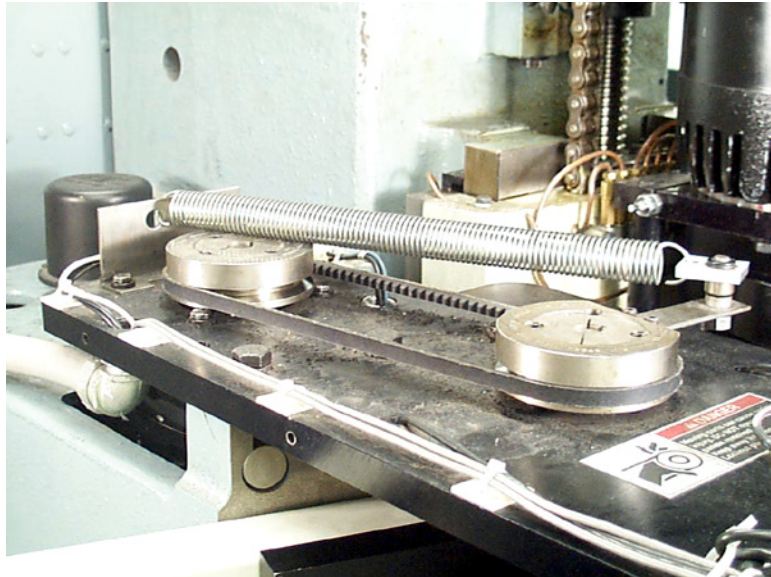

Figure 5-9 Remove ATC Upper Cover

- 2) Remove tension spring.
- 3) Loosen 4 screws holding motor.

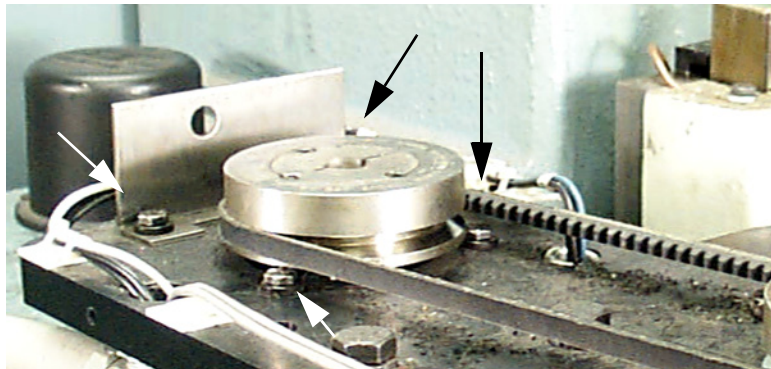

Figure 5-10 Loosen Screw that Hold Motor

- 4) Remove belt. Install motor mounting screws.

- 5) Install the new belt. Using a screwdriver or small pry bar, apply force to move the motor back, then tighten the motor mount bolts.

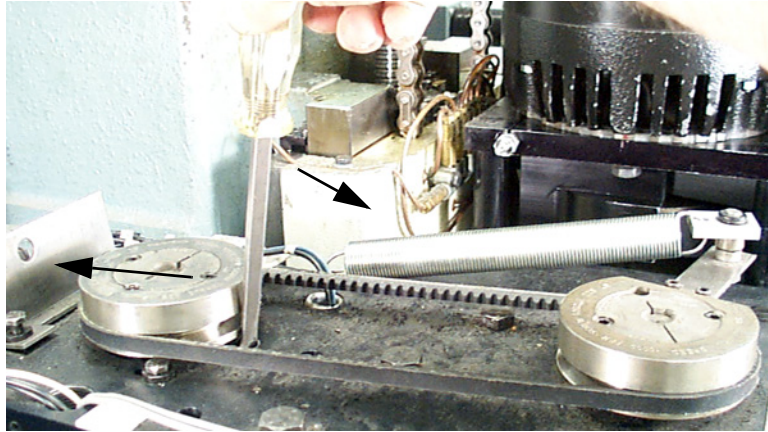

Figure 5-11 Install New Belt

Note: When the belt tension is correct you should have .250" (6.35mm) belt reflection with a 6lb. pull. If the belt is too tight or too loose the ATC will slam at one end of its travel. The belt is designed to slip at each end of the travel. If you do not have a pull gauge, squeeze the belt with your thumb and index finger in its center. If the inside of the belt is about even with the large mounting bolt, the belt tension is about right.

- 6) Reinstall the tension spring. Reinstall the cover.

ATC Motor Replacement Procedure

Replacing the Turret Motor on a Geneva Wheel ATC

- 1) Remove the ATC cover.
- 2) Remove the Motor cover.
- 3) Disconnect the Molex connector with the motor wires.
- 4) Disconnect the ground wire.
- 5) Remove the four bolts holding the motor down.
- 6) Remove the motor.
- 7) Measure the distance from the bottom of the motor to the top of the Geneva gear.
- 8) Remove the Geneva gear.

- 9) Install Geneva gear on replacement motor at same position as on old motor.
- 10) Place motor in ATC and slide it firmly toward the Head.
- 11) Tighten motor mounting bolts.
- 12) Connect ground wire and Molex connector.
- 13) Perform alignment procedures.
- 14) Replace the covers.

Replacing the Turret Motor on a Servo Turret ATC

- 1) Remove the ATC cover.
- 2) Remove the motor cover.
- 3) Disconnect both the encoder and the motor Molex connectors.
- 4) Remove the four motor mounting bolts.
- 5) Remove the belt from the pulley and remove the motor.
- 6) Place the replacement motor (MTR-0144) in mount and replace the belt.
- 7) Install the four mounting bolts.
- 8) Pull motor upward so the belt is snug and tighten the mounting bolts.
- 9) Connect the encoder and motor connectors.
- 10) Perform alignment procedures.
- 11) Replace covers.

Replacing the Slide Motor

- 1) Remove the ATC cover.
- 2) Remove the large tension spring.
- 3) Disconnect the Molex connector for the slide motor.
- 4) Loosen the four motor mount bolts so motor can move to release belt tension.
- 5) Remove the belt.
- 6) Remove the three large bolts holding the slide motor mounting plate.
- 7) Pull the motor mounting plate up and lay it on its side.

- 8) Remove slide motor.
- 9) Install replacement slide motor.
- 10) Re-install motor mounting plate.
- 11) Connect the Molex motor connector.
- 12) Install belt. (see belt replacement procedure)
- 13) Install tension spring.
- 14) Perform alignment procedures.
- 15) Replace covers.

Turret Factor Setting

This parameter is set at the factory. This parameter should not be changed unless the turret motor has been replaced or the tool turret rotation is over or under shooting.

Note: VMCs equipped with the Servo Turret ATC, instead of the Geneva-driven ATC, must ALWAYS have a turret factor of 1.

A proper turret factor will have the Geneva driver positioned as in Figure 5-11-a.

An incorrect turret factor will have the Geneva driver positioned approximately as shown in Figure 5-11-b

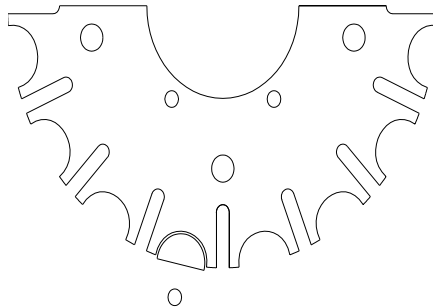

Figure 5-12 -a Correct Geneva adjustment

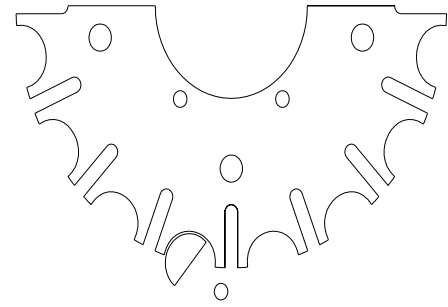

Figure 5-11-b Incorrect Geneva adjustment

Pulley Alignment

Fadal Spindle Pulleys have lines for the orientation alignment of the spindle. To achieve proper alignment, the line on the top of the spindle must be aligned with one of the three lines on the spindle pulley.

- The **Long Line**, which is for all Machines except for VMC 4020 with 30 tool ATC, and the Dual Arm ATC.
- The **Short Line**, which is for VMC 4020 machines with 30 tool ATC.

The Long and Short Lines are next to one another.

- The new pulleys will also have a **Third Line**, which is for the Dual Arm ATC.

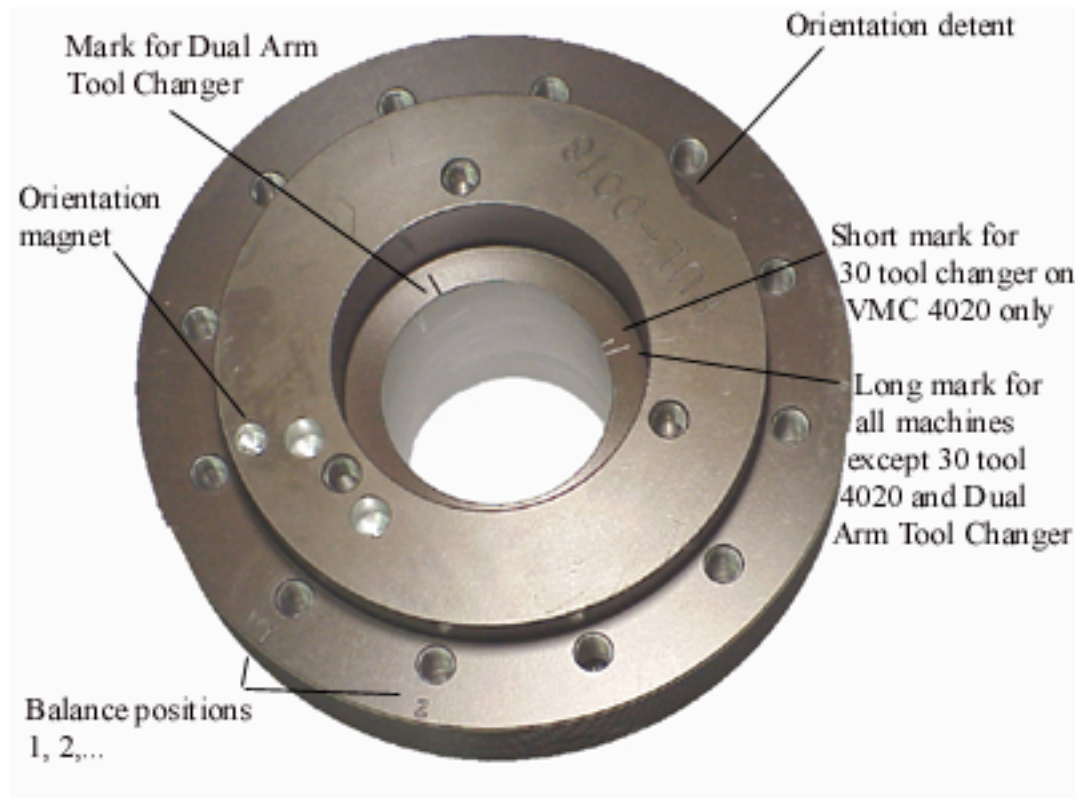

Figure 5-13 Fadal Spindle Pulleys

Dual Arm Tool Changer

Tool Changer Specifications

Type of Tool		CAT-40/BT-40
Number of Tools		24
Maximum Tool Diameter		
	All Pockets Full	100mm (4in.)
	Adjacent Pockets Empty	180mm (7.2in.)
Maximum Tool Length		350mm (13.8)
Tool Weight		
	Maximum	6.5kg (14.3lbs.)
	Average	5.0kg (11lbs.)
Tool Magazine Drive Source		
	Motor Voltage	220VAC, 3 Phase
	Air Pressure	5.7kg/sqcm (12.5psi)

Sub-Assemblies

INDEX MECHANISM

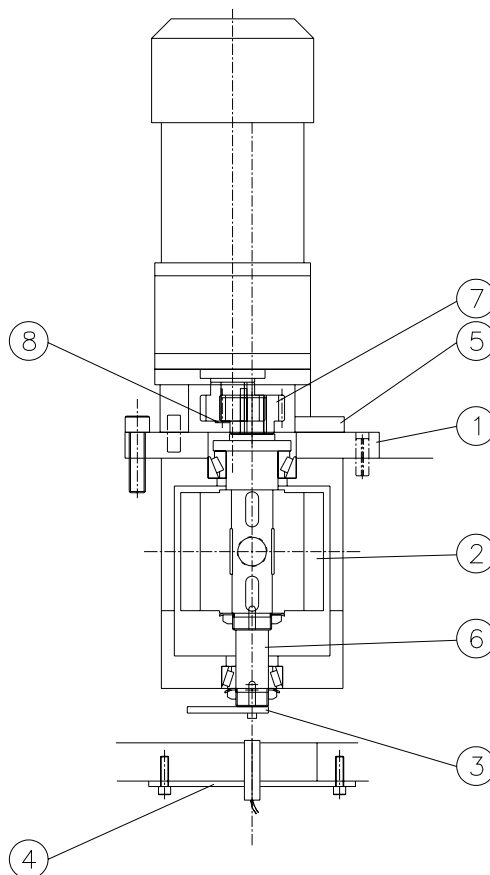

Figure 5-14 Index Mechanism

No.	Part Description
1	Cam Base
2	Cylindrical Cam
3	Sensor Block
4	Proximity Switch Bracket
5	Motor Base
6	Driving Shaft
7	Gear
8	Gear Plate

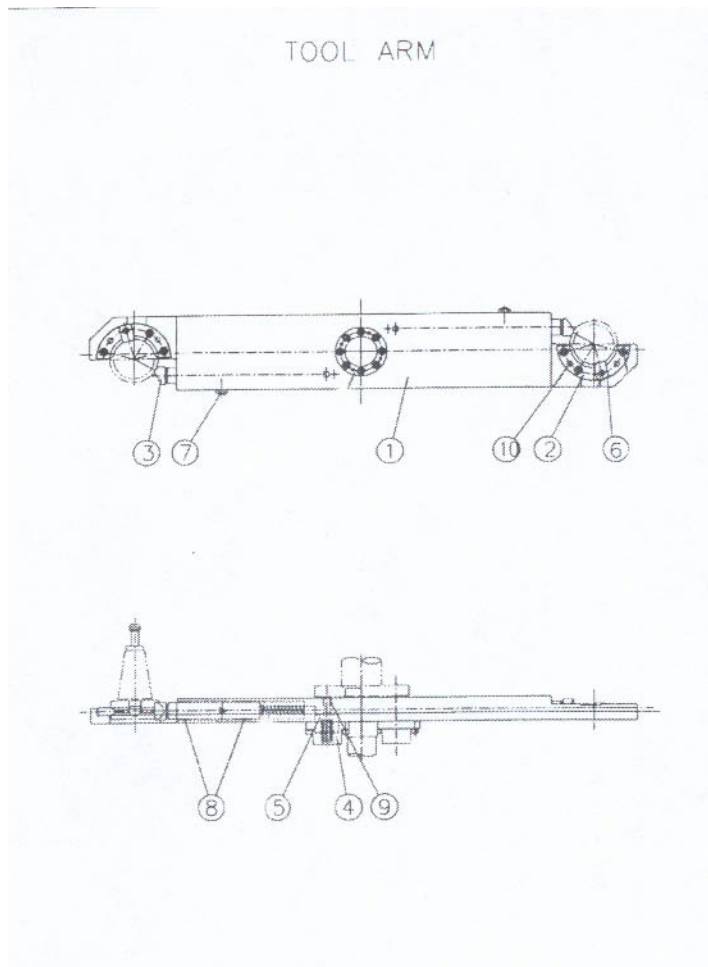

Figure 5-15 Tool Arm

No.	Part Description
1	Tool Arm
2	Tool Draw
3	Tool Holding Rod
4	Spring Cover
5	Plunger
6	Positioning Key
7	Positioning Screw
8	Self Lubricating Bearing
9	Self Lubricating Bearing
10	Spring Pin

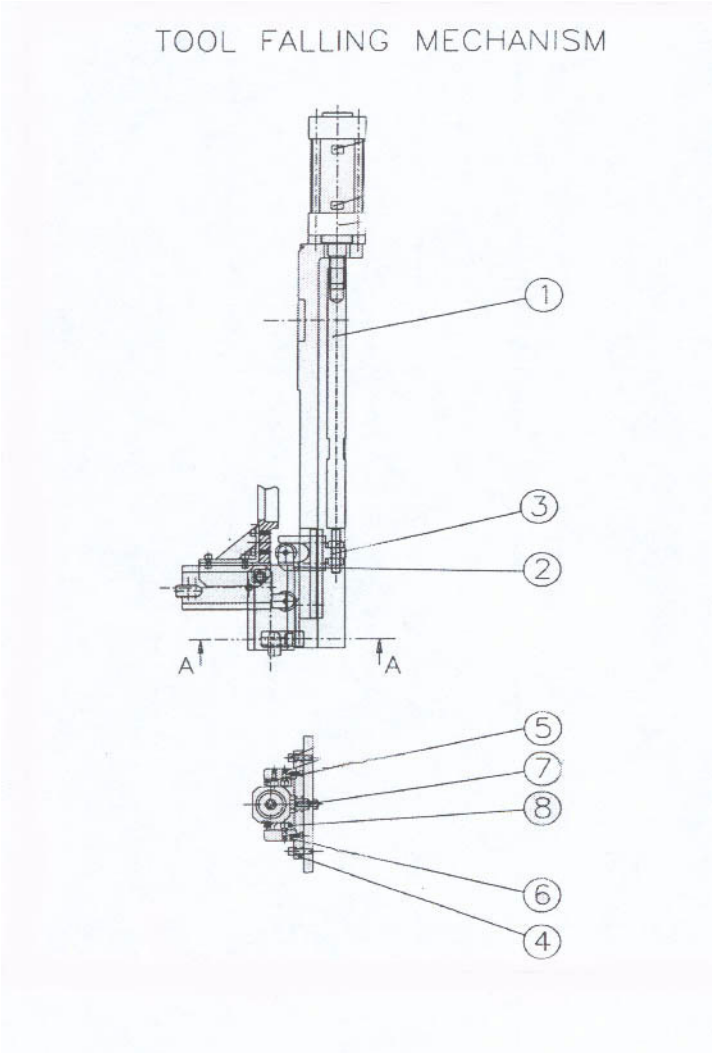

Figure 5-16 Tool Falling Mechanism

No.	Part Description
1	Tool Rod
2	Sliding Block
3	Sliding Block Cover Plate
4	Positioning Block Stand
5	Positioning Sliding Block (1)
6	Positioning Sliding Block (2)
7	Fixing Base of Tool Pot
8	Positioning Sliding Block (3)

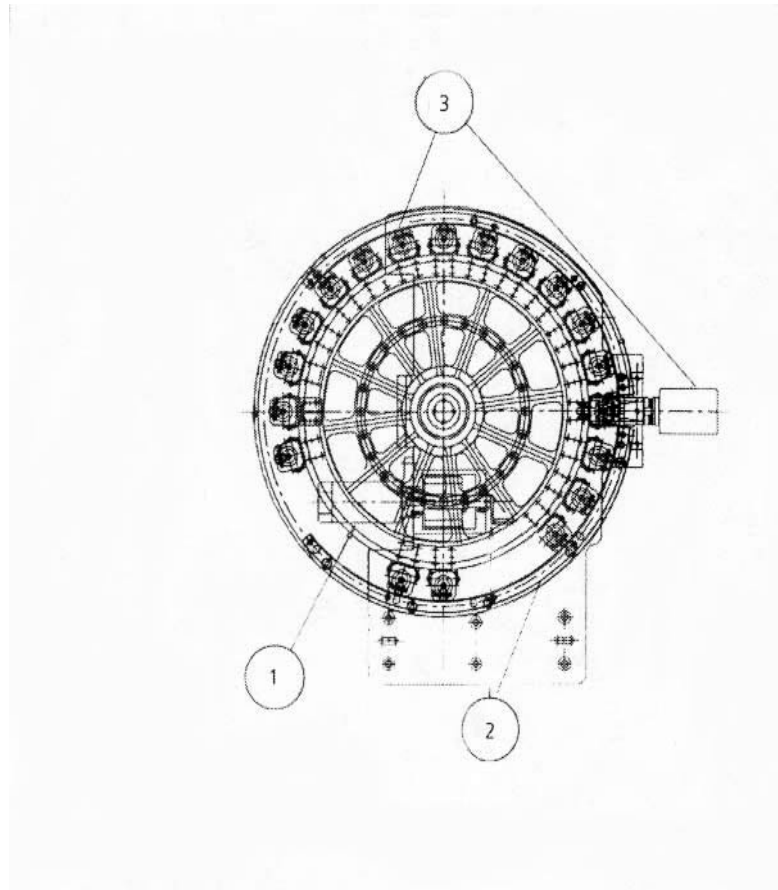

Figure 5-17 Tool Turret

No.	Part Description
1	Tool Magazine Motor
2	Tool Magazine
3	Tool Buckets

**Installation &
Testing****Dual Arm ATC Installation and Alignment:**

- 1) Verify that all bolts are properly tightened.
- 2) Remove the main cover surrounding the ATC arm and falling mechanism.
- 3) Remove the oil inlet plug and fill the ATC oil reservoir with lubricant (MOBIL DTE OIL HEAVY MEDIUM) to approximately 1-1/2 gallons or 5 liters. Observe the sight glass to verify that the oil reservoir does not over fill (see Figure 5-18, positions 1 and 2). The alternative way to fill the oil reservoir is by utilizing the plugged air vent on top and to the rear of the main ATC casting. This does not require the removal of the main cover.

Note: Use caution during installation. Check all of the control elements for damage (sensors and wires).

- 4) Install the ATC onto the machine using: 8 1/2 – 13 X 1 3/4 inch UNC-2B HHC hex cap screws with eight split lock washers.
- 5) Do not tighten the mount bolts completely. They will need to remain loose to allow for the front to back and side to side alignments to be made.
- 6) Using a crane or forklift, position the ATC as needed to assist in the adjustments.
- 7) Install the alignment fixture to the spindle mount surface using two 3/8-16X1” bolts. Verify that the fixture is centered. Slowly tighten the fixture. Keep the fixture centered throughout the procedure.

Note: Before proceeding to the next step, review the applicable job sheet to confirm that the ATC is set-up for the specified tool holder configuration (CAT-40 or BT-40). The tool grippers and tool orientation (or positioning) keys may need to be changed if the tool holder configuration needs to be changed.

- 8) Remove the socket head cap screws plus the 2-8mm Roll pins mounting the gripper onto the ATC arm body (the gripper has 3 bolts for the 4525 and 4 for the 3020 and 6535).
- 9) Install and tighten the gripper with the proper tool orientation (or position) key. See Figure 5-17, positions 1, 6, and 7.
- 10) When manually rotating the tool arm, use the proper socket on top of the tool changing mechanism motor shaft. The drill motor should turn forward or CW.
- 11) While rotating the ATC arm, pull the motor brake switch up. This is the electromagnetic brake that will be holding the motor back from turning

smoothly. The switch is located on top and to the front of the ATC motor (the switch must be held up). See Figure 5-17, position 3.

- 12) The ATC arm body will turn 80 degrees for the 3020, 65 degrees for the 4525 and 35 degrees for the 6535. The tool falling mechanism will engage. The arm will then move down and turn 180 degrees, for both the 3020 and 4525, to exchange gripper positions. Stop turning the motor when the arm reaches the down position.
- 13) With the falling mechanism in the down position, put the proper tool holder type in the forward tool gripper and orient the tool so that it goes into the arm gripper with the deepest relief engaging the gripper key way.
- 14) To install the tool holder manually, it will be necessary to push the plunger mechanism down, to release the pressure of the tool holding rod. See Figure 5-17, positions 2 and 3.
- 15) Begin manually turning the motor of the ATC. The falling mechanism will start moving back up. Stop turning the motor when the arm reaches the top most position or has reached the dead spot, before changing direction.
- 16) JOG the Z-axis down and position the head and spindle fixture at or near the normal Z-axis cold start position. This will put the tool holder up inside the fixture. Do not allow the sides of the tool holder to touch the Inner Diameter (I.D.) of the spindle fixture. For the Siemens Control, perform the following steps: Press the JOG hard key, then the MPG hard key, and use the MPG hand wheel to jog the Z-axis into position.
- 17) If the ATC is off alignment, adjust the front to back and side to side as needed, until the tool can be inserted into the spindle fixture to a minimum of 1".
- 18) Put a small level on the ATC arm body to check the level. Typically, this would be the same level adjustment as the base casting. Check the base way, with the small level, as the reference position.
- 19) With a dial-caliper (Vernier-Caliper) or a depth micrometer, check the distance from the outer diameter (O.D.) of the tool holder to the O.D. of the spindle fixture using the fixture through holes. Split the difference between the front to back readings.
- 20) Check the distance between the O.D. of the tool holder to the O.D. of the spindle fixture, using the through holes, and split the difference between the side to side readings. See Figure 5-16, positions 4, 5, 6 and 7.
- 21) The reading that was obtained in step #20 will be the shim size required.

- 22) If required, install the shims in groups of twos, one along the top the row of the ATC mount bolts and one underneath the bottom row of mount bolts. See Figure 5-18, positions 4,5, and 6.
- 23) With a forklift or crane still connected to the ATC, loosen the support bolts to reposition the ATC. Using a rubber mallet, shift the tool changer forward or backward, or bring the front up or down. The forward and backward movement of the ATC is used to adjust the horizontal straightness. The front of the tool changer being moved up or down is used to adjust the level.
- 24) To properly adjust the side to side position of the ATC, use one of the following methods:
 - a. Remove one of the shims from in between the main casting and the extended mount bracket. These items were used to compensate for dimension tolerances that resulted from the manufacturing process. Shims may or may not be present.
 - b. Remove the ATC extension mount bracket and mill it down to the proper dimension and then reassemble the part to the machine (This is only in the case of not having shims present between the ATC and extension bracket).
 - c. Manufacture shims that will be inserted between the extended mount bracket and the column casting of the machine. Loosen the support bolts to allow the shims to be inserted in along the top and bottom rows of the ATC mount bracket, at the column.
- 25) Recheck the level and alignment of the ATC for front to back and side to side. If necessary, re-adjust the alignment and tighten the ATC into position. See Figure 5-19.
- 26) Repeat above steps for the opposite tool gripper to ensure consistent alignment before pinning the ATC into its final position.
- 27) Drill and ream the four dowel-pin holes to accept tapered pins. The drill size is 5.953mm. The tapered Reamer size is: #5.

Note: When reaming the holes for the dowel pins, observe that the pins do not extend past the edge of the hole by more than 6.35mm (1/4 in.).
- 28) Install four #5 tapered dowel-pins into the ATC arm mount at the column. See Figure 5-18, position 4.
- 29) Switch to the reverse direction on the drill motor to manually rotate the tool arm back, so the tool holder can be removed.

- 30) While rotating the ATC arm, pull the motor brake switch up. This is the electromagnetic brake that will be holding the motor back from turning smoothly. The switch is located on top and to the front of the ATC motor (the switch must be held up). See Figure 5-18, position 3. When the motor has reached the lowest position, press the plunger and remove the tool holder.
- 31) Start turning the ATC motor again, in the same direction as in step #30. The falling mechanism will reverse, sending the arm back up. At the highest position, the arm body will turn back (80 degrees for the 3020, 65 degrees for the 4525 and 35 degrees for the 6535) to the stand by position 1 (ATC Home Position).
- 32) Remove the spindle fixture from the head.

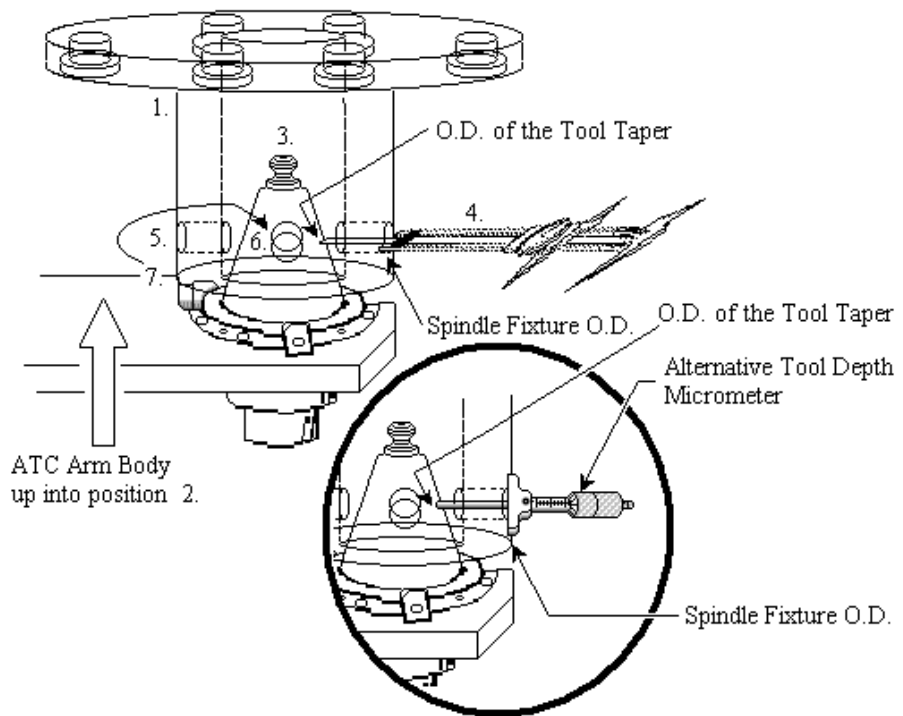

Figure 5-18 Manual Rotation of Tool Arm

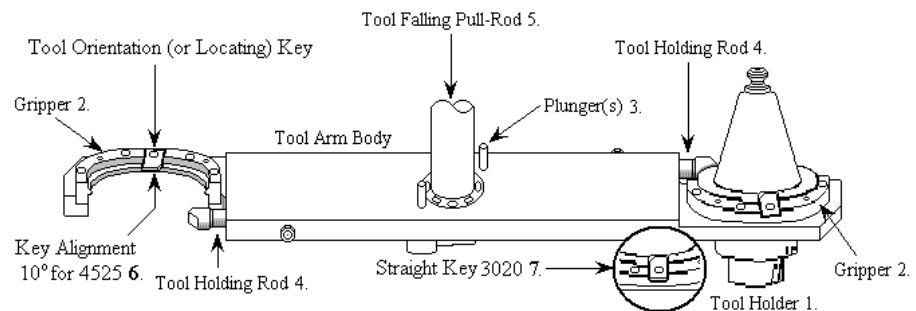

Figure 5-19 Pull Motor Brake Switch

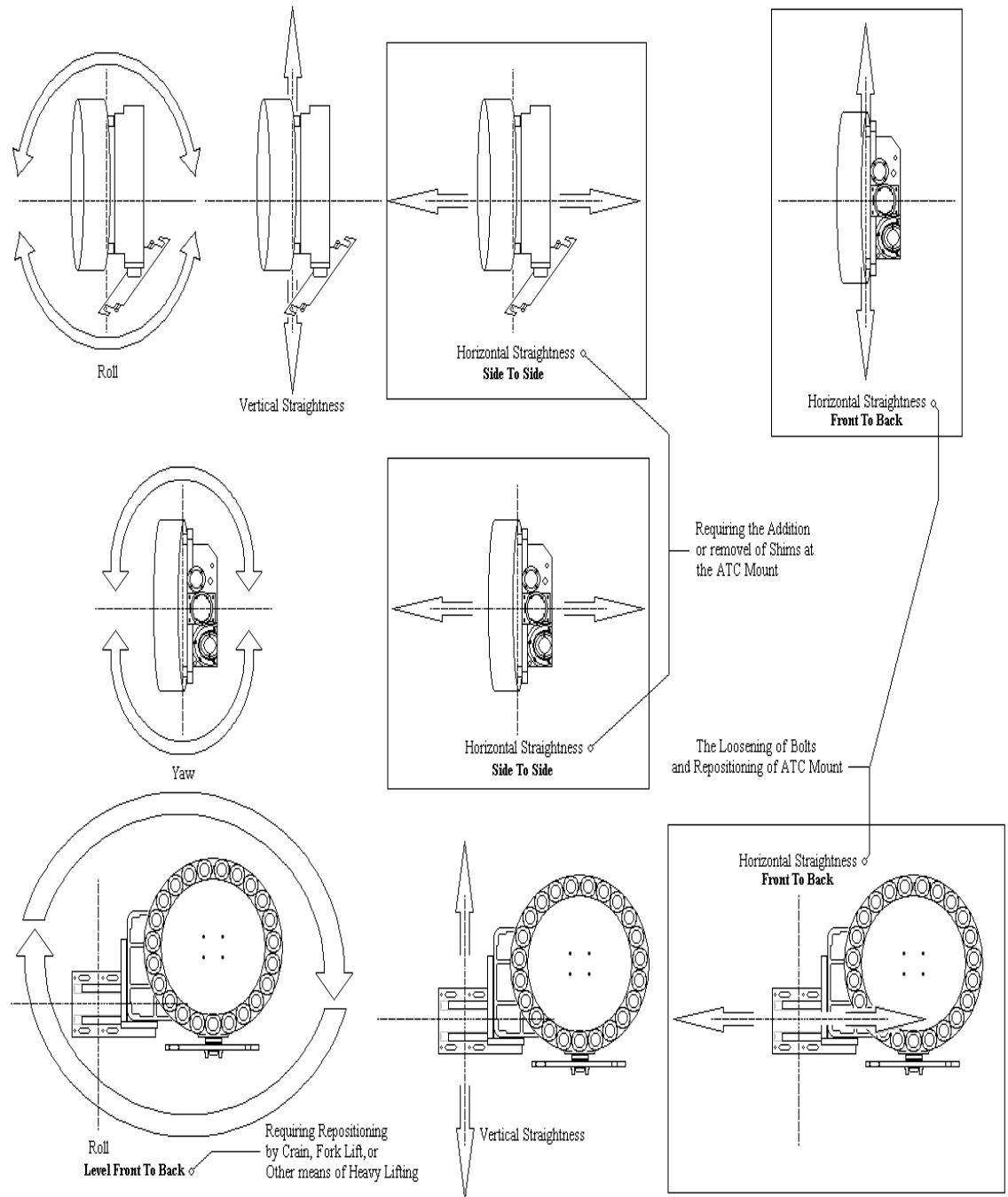

Figure 5-20 ATC Movement

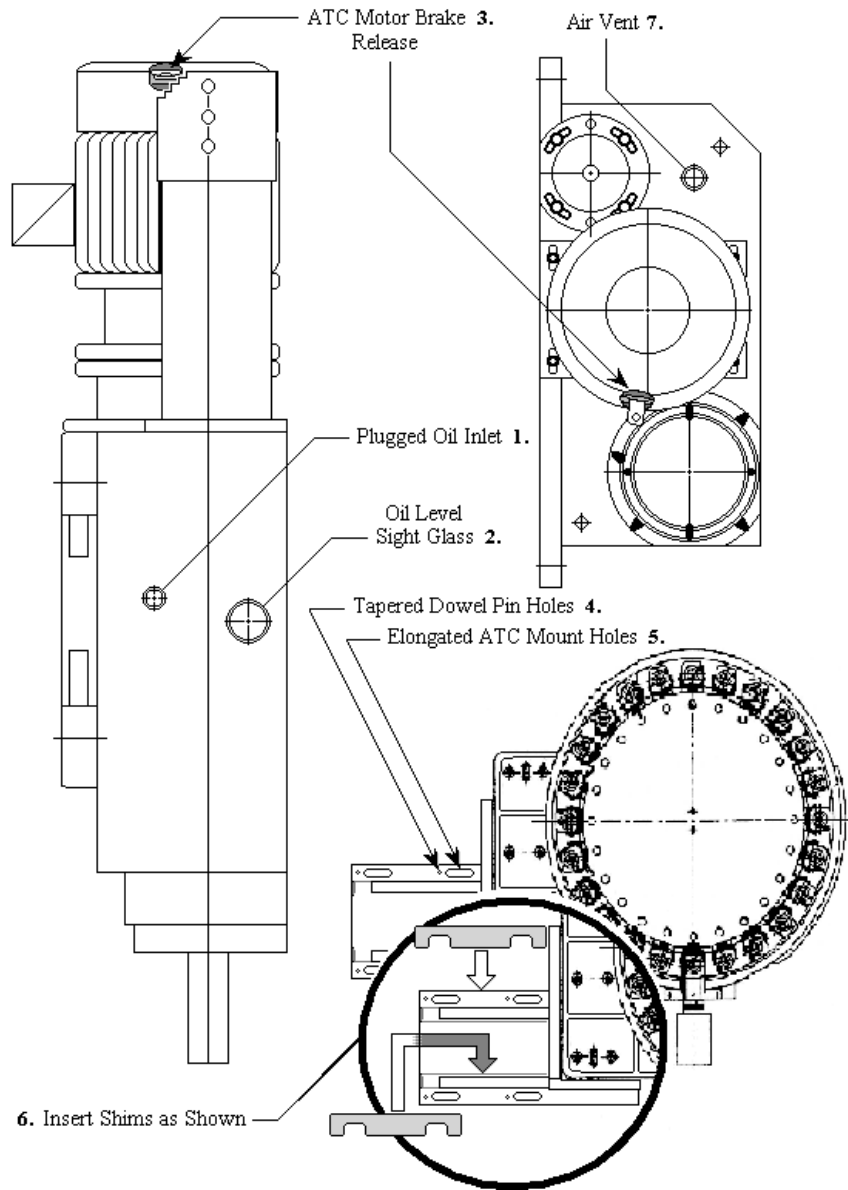

Figure 5-21 Engage Gripper Key Way

Software & Mechanical Test

Perform all of the following actions at the pendant keypad. Align all of the axes to the cold start marks.

- 1) Press the MANUAL button until ENTER NEXT COMMAND is displayed.
- 2) Type SETTO, and press the ENTER button. This will set the tool position to tool number 1.
- 3) Type CS, and press the ENTER button to Cold Start the VMC.

- 4) Type MD, and press the ENTER button. This will enter the VMC into the Manual Data Input (MDI) mode.
- 5) Type M6 T2, and press the ENTER and the START buttons.
- 6) Verify the following:
 - a. The proper tool number is displayed on the monitor.
 - b. A proper tool change was made (proper tool and position).
 - c. The Z-axis returns to Z0, cold start position.
- 7) Press the MANUAL key.
- 8) To test the high speed tool change, enter and run the following program:
Type MD, and press the ENTER button.

```
Enter:  
T-2  
M6 T2  
T-3  
G4 P5000  
M6 T3  
T-5  
G4 P5000  
M6T2
```

Press the SPACE BAR to toggle user menu on.

Press the AUTO button, and then press the START button.

Verify the following:

- a. The proper tool number is displayed on the monitor.
- b. A proper tool change was made (proper tool and position).
- c. The Z-axis returns to Z0, cold start position.

Press the MANUAL button to return to the ENTER NEXT COMMAND screen.

Set-Up CNC Set-Up

The VMC is shipped with the parameters set for Dual Arm Tool Changer. Check the TOOL CAPACITY parameter on the PARAMETERS page. On the CNC control, type SETP and then press the ENTER button. The parameter for the Dual Arm is 4.

Orientation Set-Up

When installing the pulley on the spindle, use the third orientation mark to properly line up the spindle with the tool changing arm. The third orientation mark is located approximately 100 degrees from the standard orientation marks.

Cold Start Set-Up

- 1) Verify that the VMC has been cold started. Type M19, to orient the spindle, and press the ENTER button.
- 2) Press the JOG button, to enter the JOG mode, and slowly move the Z-axis all the way up.
- 3) Press the MANUAL button, to enter the ENTER NEXT COMMAND mode.
- 4) Type DI, press the ENTER button, type DD, and press the ENTER button (this is the diagnostic mode for the Dual Arm Tool changer).
- 5) Use the 3 button on the pendant keypad to index the tool arm over to the spindle.
- 6) Press the MANUAL button to return to the ENTER NEXT COMMAND mode, and press the JOG button.
- 7) Move the Z axis down until the front key of the spindle is in the key-way of the tool.
- 8) Measure a distance of .020" - .030" from the bottom of the spindle key to the bottom of the tool arm key-way.
- 9) Cold start the machine from this point.
- 10) Enter the Diagnostic Mode again, and use the 4 button on the pendant keypad to move the tool arm back to the center position.
- 11) Press the MANUAL button and type SV. Press the ENTER button (this is the Survey table). Press the D button, to move the cursor down, until the ZERO OFFSET is selected. Type the number 0 and press the ENTER button. The Zero Offset is now 0. Press the MANUAL button, to enter the ENTER NEXT COMMAND mode.
- 12) Using an extended base, place an indicator on the table and touch the indicator to the bottom of the spindle. Zero the indicator.
- 13) Type CS, and press the ENTER button, to Cold Start the machine. Press the JOG button and jog the Z axis up. Slide the indicator back under the spindle and jog the head down until the zero reading is obtained on the indicator. Move the indicator .020" - .030" above the zero reading. Look on the monitor and note the Z axis value on a sheet of paper.

14) Enter the Survey Table and select the ZERO OFFSET. Type the number that was recorded from the monitor. Press the ENTER button. Press the MANUAL button, to return to the ENTER NEXT COMMAND screen and press the JOG button, to enter the JOG mode.

Note: If the VMC is equipped with a Siemens Control, stop after step number 14.

15) Jog the Z axis down 3.25 inches and type SETCS. Cold start the machine. Jog the Z axis up 3.25". Enter the Diagnostics Mode for the Dual Arm Tool Changer, and use the 3 key on the keypad to move the tool arm in to the spindle. Verify the .020" - .030" gap between the bottom of the spindle key and bottom of the tool arm key way.

16) Use the 4 key on the keypad to move the tool arm back to the center position. Press the MANUAL button, then the JOG button and jog the Z axis back to the cold start position.

Tool Loading Procedures

- 1) Press the MANUAL button to enter the MANUAL DATA INPUT mode.
- 2) Type M19 and press the ENTER button, to orient the spindle.
- 3) Press the MANUAL button, to return to ENTER NEXT COMMAND. Press and hold the TOOL IN/OUT button and insert tool number one into the spindle (If the tool is a CAT-40, then the tool should be inserted with the shallow key slot facing the back of the spindle and the deep key slot facing the operator. If the tool is a BT-40, then insert the tool with the set screws facing the back of the spindle).
- 4) Use the Clockwise (CW) and Counterclockwise (CCW) buttons, located on the pendant, to position the tool turret. Type SETTO to establish tool position for the control.
- 5) Press the MANUAL button, to return to the MANUAL DATA INPUT and type M6T2. Press the ENTER button, then the START button. This will put tool number one in the tool carrier and leave the spindle open for tool number two to be inserted (M is the programming code for a tool change and T2 is for tool number 2).
- 6) Repeat step number 5, substituting the appropriate tool number, until all of the desired tools have been loaded.

Operation

Programming

The Dual Arm Tool Changer uses the same programming codes as the Geneva driven and Servo Turret tool changers. To optimize the tool to tool change time,

a T minus (T-) command is used to pre-stage the next tool. The following program is an example of the programming for this tool changer, and can be used in the *Auto Mode* or the *Manual Data Input (MDI) Mode*.

Sample Program:

```

01
M6T1 (make a tool change to tool number 1)
S1000M3
T-4 (pre-stage tool number 4). This is different from the T minus command that
is used with the Geneva type tool changer, which positions the tool changer at
slot number 4 to give adequate tool clearance.

```

```

-----
program
-----

```

```

M6T4 (Tool change to tool number 4)
S1000M3
T-1 (pre-stage tool number 1):

```

Note: Separate the M6T# line and the T-# line with at least one line of different coding.

Manual Operation

The tool changer can be manually operated in the Diagnostic Mode. This mode will be used to service the tool changer or complete a systems check.

- 1) On the keypad, type DI, and press the ENTER button. Then type DD and press the ENTER button. This will put the machine in the diagnostic mode for the Dual Arm Tool Changer.
- 2) Use the menu to operate the desired function.

WARNING

Verify that the head is 3.25” or more above the machine cold start position before moving the tool arm in the forward or reverse direction.



1	Bucket Up
2	Bucket Down
3	Move Arm Forward
4	Move Arm Reverse
6	Reset 1330 Card
0	Sensor Status
' _ '	Pocket Status

- 3) Pressing the "0" button will display the sensor status at the bottom of the diagnostics page. This is where the status of each sensor can be monitored during manual operation.

Sensors

Home Position Bucket Up Drawbar Down
Tool Arm Stop Bucket Down Emergency Stop
Tool Change Pos Tool Count Interlock

If the tool changer arm or bucket are out of position, the DI/DD mode must be used to move any component.

Using the DD Command

To view the tool positions, use the ENTER NEXT COMMAND screen and type DD. While viewing the tool positions, the operator can:

- 1) Press the CW/CCW buttons, on the pendant, to change the slot that is lined up with the spindle. This change will be highlighted by an asterisk (*), placed next to the appropriate number.
- 2) Choose option number 1, SWAP TOOLS, which will change the tool in the spindle with the tool in the bucket that is lined up with the spindle. When the tools are switched, the monitor will display the tool that is in the spindle.
- 3) Choose option number 2, SORT TOOLS, which will sort all of the tools automatically, placing each tool with its respective slot number. When the tool changer has finished sorting the tools, tool number 1 will be in the spindle.

Sys 101.4 Software Update.

A recovery procedure has been developed for the case where the Turret on Dual Arm Tool Changers has been commanded to rotate, and E-Stop has been implemented prior to completion of the rotational move, possibly interrupting the Tool Count and mislocating the bucket at "Ready" position.

Should this case occur and the Turret is mislocated between buckets, the error message, "AMBIGUOUS BUCKET POSITION, VERIFY POCKET # WITH SETTO, #" will appear.

- 1) 1. From the command line, type "DD".
- 2) 2. This will display the Tool Bucket and Tool Number table, and identify with an asterisk which Bucket is expected to be at the "Ready" position.

- 3) 3.If the Turret is mis-positioned, and the tools are NOT out of sequence, then press TURRET CW or CCW until BUCKET #1 (not TOOL #1) has been rotated to the "Ready" position at the bottom.
- 4) 4.Type "SETTO,1" at the command line to reset Bucket #1 to the "Ready" position, and move the , ' asterisk in "DD" to Bucket 1. This command can be used as "SETTO,xx" where "xx" is the BUCKET number at the "Ready" position. It does NOT reset Tool Numbers.
- 5) 5.If the tool sequence is still incorrect, then remove the tools from the Tool Changer, move Bucket #1 to the "Ready" position with TURRET CW or CCW, type "SETTO" from the command line, and reload all of the tools. "SETTO" resets all of the Tool Numbers to that of the Bucket Numbers.

Versions

SYS 101.4 is available in English non-CE only.

Troubleshooting

Symptom	Possible Problem	Corrective Action
Tool disc does not stop at the locating position	<ol style="list-style-type: none"> 1) The brake is not working. 2) The distance between the proximity switch and sensor point is too long. 	<ol style="list-style-type: none"> 1) Verify that the wiring of the electronic brake is correct and that the brake is in proper working condition. 2) Close the distance between the proximity switch and the sensor point.
The tool disc keeps rotating	<ol style="list-style-type: none"> 1) The proximity switch is faulty. 2) The distance between the proximity switch and the sensor point is too long. 	<ol style="list-style-type: none"> 1) Install a new proximity switch. 2) Close the distance between the proximity switch and the sensor point.
The bracket of the tool pot is deformed	<ol style="list-style-type: none"> 1) The tool disc is rotating while the tool is falling. 	<ol style="list-style-type: none"> 1) Install and adjust a new set of brackets. Insert a dowel pin into the tool disc.
The tool disc has jammed while rotating.	<ol style="list-style-type: none"> 1) The C snap ring is loose or the parts of the tool pot fixing base are broken. 2) The cylinder is moving while the tool disc is rotating. As a result, the tool pot is stuck at the tool falling position. 	<ol style="list-style-type: none"> 1) Remove and replace the snap ring or the tool pot bracket. 2) Verify that the bracket is not deformed. If the sliding block of the tool falling and roller are broken, repair or replace them.

Sequence of Events for Dual Arm-ATC Operation—Fadal Control

- 1) Feedback.

- 2) Tool Up sensor (Magnetic reed switch mounted at Bottom of Air Cylinder-normally open – “Tool Up” LED).
- 3) Tool Down sensor (Magnetic reed switch mounted at Top of Air Cylinder-normally open -“Tool Down” LED).
- 4) Above sensors have a LED mounted into the sensor and 1330-0 card that is lit when switch is closed.
- 5) Arm Stop (Proximity current sensor #1 mounted at Top on Arm – “Stopping Sensor” LED).
- 6) Arm Tool (Proximity current sensor #2 mounted at Center on Arm – “Arm at Spindle” LED).
- 7) Arm Home (Proximity current sensor #3 mounted at Bottom on Arm – “Arm at Home” LED).
- 8) Tool Count sensor (Proximity current sensor mounted under Turret Motor – “Tool Count” LED).
- 9) Drawbar sensor (Hall Effect sensor mounted under Drawbar Cylinder – “Drawbar” LED).

Above sensors have an LED mounted on the 1330-0 card that is lit when switch is closed.

Errors

#	Error Message	Description
1	CAROUSEL SOLENOID FAILURE (OR SENSOR)	
2	DRAWBAR SOLENOID FAILURE (OR NO AIR)	The Drawbar Cylinder could not be moved down to extract tool. Check Air Supply. Check Tool.
3	DRAWBAR SENSOR FAILURE	The Drawbar Cylinder piston could not return home.
4	ATC ARM IS NOT IN HOME POSITION	The ATC Arm did not arrive at ATC Home.
5	ATC BUCKET UP SOLENOID/SENSOR FAILURE	The ATC Bucket Cylinder did not arrive at TOP.
6	ATC BUCKET DOWN SOLENOID/SENSOR FAILURE	The ATC Bucket Cylinder did not arrive at BOTTOM.
7	ATC ARM SOLENOID SENSOR/HOME SENSOR FAILURE	The ATC Arm could not move away from HOME.
8	ATC TOOL ARM OBSTRUCTED	The ATC Arm did not arrive at Spindle.
9	ATC TOOL SENSOR FAILURE	The ATC Arm TOOL Sensor was not seen.

#	Error Message	Description
10	ATC TOOL CLAMPING FAILURE	The ATC Arm could not move down from Spindle.
11	ATC TOOL UNCLAMPING FAILURE	The ATC Arm could not leave Tool Holders.
12	ATC INTERLOCK IS ON	
13	ATC COMMUNICATION ERROR WITH 1330-CARD	Can't communicate between the 1330 and 1400.
14	ATC AMBIGUOUS BUCKET POSITION	ATC Bucket is neither UP nor DOWN. Neither reed switch is seen.
15	ATC AMBIGUOUS TURRET POSITION	ATC Turret is in-between Buckets. Turret Sensor is not seen.

DA-ATC Tool Change Cycle—Fadal Control

- 1) Initiate Tool Change -- M6.
- 2) Spindle OFF (M5). Orient Spindle (M19). Check for Orient Switch feedback.
- 3) If feedback from Spindle Orientation Hall Effect switch, then Spindle is Oriented, STOP Spindle. K7 and K9, K3 and K4 OFF.
- 4) Begin a new one second timer to initiate "Bucket DOWN" cycle.
- 5) Enable 1330/K2 to power Air Valve to move Bucket DOWN.
- 6) If Air Cylinder top reed switch is OPEN and the bottom reed switch is CLOSED, then stop the timer. Proceed to 4.
- 7) If timer times out, the Bucket did not move down, and if top reed switch is CLOSED and bottom reed switch is OPEN, then get message #6—ATC BUCKET DOWN SOLENOID/SENSOR FAILURE. Halt system.
- 8) Or, if timer times out, the Bucket did not move down, and if top reed switch is OPEN and bottom reed switch is OPEN, then get message #14—AMBIGUOUS BUCKET POSITION. Halt system.
- 9) Begin a new one second timer for "Arm to Spindle" cycle, and activate Triacs for Arm Motor to move.
- 10) Enable 1330/K4 relay to CLOSE 3-phase contactor.
- 11) Stop the timer as soon as the Arm moves away from its home position, and the ARM STOP and ARM HOME sensors report that Arm is away. This verifies that the ARM STOP and ARM HOME signals are working properly. Then proceed to 5.

- 12) If the timer times out, and therefore the arm has not moved from the ARM HOME position, then get message #7, ATC ARM SOLENOID SENSOR/HOME SENSOR FAILURE. Halt system. Check Overload LED on 1330, Arm Motor Drive Belt, Contactor, move Arm manually by turning top of Arm Motor shaft—checking for resistance, check for dragging brake in Arm Motor, and fuses ahead of Contactor.
- 13) Begin a new one-second timer to initiate “Arm Approaching Spindle/ Bucket” cycle.
- 14) As soon as the ARM STOP and ARM TOOL signals are seen, stop the timer, disable 1330/K4 relay to disconnect Contactor to power OFF Arm Motor. Proceed to 6.
- 15) If the timer times out, the arm has not arrived at Spindle and Turret Bucket. Get message # 8—ATC TOOL ARM OBSTRUCTED or if ARM STOP sensor was seen and ARM TOOL was not, get # 9--ATC TOOL SENSOR FAILURE. Halt system. Check Overload LED on 1330, Arm Motor Drive Belt, Contactor, move Arm manually by turning top of Arm Motor shaft—checking for resistance, check for dragging brake in Arm Motor, and fuses ahead of Contactor.
- 16) Begin a new one-second timer to initiate “Drawbar Down” cycle.
- 17) Enable the 1330/K1 relay to power Air Solenoid to Drawbar Cylinder.
- 18) As soon as Drawbar Cylinder Hall Effects switch is seen, stop the timer. Proceed to 7.
- 19) If timer times out, then Tool could not be extracted from Spindle. Get message #2—DRAWBAR SOLENOID FAILURE (OR NO AIR). Halt system. Check Drawbar Cylinder Hall Effects switch and its adjustment, air supply, check for broken Drawbar Cylinder piston, Drawbar Cylinder leaks, Drawbar/Belleville spring problems, and Tool Holder/Pull Stud problems.
- 20) Begin a new one second timer to initiate “Arm DOWN” cycle.
- 21) Enable 1330/K4 relay to CLOSE 3-phase contactor.
- 22) Stop the timer as soon as the Arm moves away from its Spindle position, and the ARM STOP and ARM TOOL sensors report that Arm is away. This verifies that the ARM STOP and ARM TOOL signals are working properly. Then rotate Arm 180 degrees and proceed to 8.
- 23) If the timer times out, and therefore the arm has not moved from the ARM TOOL position, then get message #10, ATC TOOL CLAMPING FAILURE. Halt system. (*This message is incorrect as the control cannot tell if the tool has been clamped or not.*) Check Overload LED on 1330, Arm Motor Drive Belt,

Contact, move Arm manually by turning top of Arm Motor shaft—checking for resistance, check for dragging brake in Arm Motor, and fuses ahead of Contactor.

- 24) Begin a new one-second timer to re-initiate “Arm Approaching Spindle/ Bucket” cycle.
- 25) As soon as the ARM STOP and ARM TOOL signals are seen, stop the timer, disable 1330/K4 relay to disconnect Contactor to power OFF Arm Motor. Proceed to 9.
- 26) If the timer times out, the arm has not arrived at Spindle and Turret Bucket. Get message # 8—ATC TOOL ARM OBSTRUCTED or if ARM STOP sensor was seen and ARM TOOL was not, get # 9--ATC TOOL SENSOR FAILURE. Halt system. Check Overload LED on 1330, Arm Motor Drive Belt, Contactor, move Arm manually by turning top of Arm Motor shaft—checking for resistance, check for dragging brake in Arm Motor, and fuses ahead of Contactor.
- 27) Begin a new one second timer for “Clamp Tool” cycle.
- 28) Disable 1330/K1 relay to stop Air Valve to Drawbar Cylinder.
- 29) If Drawbar Hall Effect Switch signal is OFF, then Tool is clamped. Stop the timer. Proceed to 10.
- 30) If the timer times out, tool is NOT clamped. Get message #3—DRAWBAR SENSOR FAILURE. Halt system. (*This error message is incorrect.*) Check for fluid buildup in Drawbar Cylinder, broken return spring, or misadjusted Hall Effect Switch.
- 31) Begin a new one second timer for the “Arm Return to Home” cycle.
- 32) Enable 1330/K4 relay to CLOSE 3-phase contactor.
- 33) Stop the timer as soon as the Arm moves away from its Spindle position, and the ARM STOP and ARM TOOL sensors report that Arm is away. This verifies that the ARM STOP and ARM TOOL signals are working properly. Then rotate arm to ATC HOME position. Proceed to 11.
- 34) If the timer times out, and therefore the arm has not moved from the ARM TOOL position, then get message #11—ATC TOOL UNCLAMPING FAILURE. Halt system. (*This message is incorrect as tool is not unclamped here.*) Check Overload LED on 1330, Arm Motor Drive Belt, Contactor, move Arm manually by turning top of Arm Motor shaft—checking for resistance, check for dragging brake in Arm Motor, and fuses ahead of Contactor.

- 35) Begin a new one-second timer to initiate “Arm Approaching ATC Home” cycle.
- 36) As soon as the ARM STOP and ARM HOME signals are seen, stop the timer, disable 1330/K4 relay to disconnect Contactor to power OFF Arm Motor. Disable Triacs to Arm Motor. Proceed to 12.
- 37) If the timer times out, the arm has not arrived at Spindle and Turret Bucket. Get message # 8—ATC TOOL ARM OBSTRUCTED. Halt system. Check Overload LED on 1330, Arm Motor Drive Belt, Contactor, move Arm manually by turning top of Arm Motor shaft—checking for resistance, check for dragging brake in Arm Motor, and fuses ahead of Contactor.
- 38) Begin a new one second timer to initiate “Bucket UP” cycle.
- 39) Enable 1330/K3 to power Air Valve to move Bucket UP.
- 40) If Air Cylinder top reed switch is CLOSED and the bottom reed switch is open, then stop the timer. Proceed to 13.
- 41) If timer times out, the Bucket did not move up, and if top reed switch is OPEN and bottom reed switch is CLOSED, then get message #5—ATC BUCKET UP SOLENOID/SENSOR FAILURE. Halt system.
- 42) Or, if timer times out, the Bucket did not move up, and if top reed switch is OPEN and bottom reed switch is OPEN, then get message #14—AMBIGUOUS BUCKET POSITION. Halt system.

Tool change cycle is completed.

PCB-0213 Dual Arm ATC Controller Card

Description and Explanation of Operation of PCB-0213 (1330-0A)

The 1330-0A is identical to the 1330-0 in terms of connections and operation with the following exceptions: a LED indicator has been added for the drawbar position sensor input, the overload sensing threshold for turret motor has been changed, and a spindle head position sensor has been added to interlock arm movement. This last change is the most significant; if the Z-axis is not at the tool change position, relays K9 and K8 will not allow the arm to move.

The 1330-0A is used on both Fadal and Siemens controls. However, the software is different for Siemens control from the Fadal control and is ordered separately from the PCB-0213.

Inputs

8-bit data port with strobe and ask for commands (bi-directional) - J4

6 Sensors - J1 and J2:

- Tool Count - proximity sensor, Namur PNP, active source
- Home position - proximity sensor, Namur PNP, active source
- Tool Change Position - proximity sensor, Namur PNP, active source
- Stopping Position - proximity sensor, Namur PNP, active source
- Drawbar down sensor - Hall Sensor, active low
- Tool Down - reed sensor, NPN, normally open
- Tool Up - reed sensor, NPN, normally open

(All sensor inputs except for drawbar can be configured for different sensors than those shown).

All sensor inputs have LEDs indicating their status. These inputs cannot be checked with a volt meter because the sensors are current devices.

+5V, +12V, GND - J5

120 VAC (J6 pin 1)

RET (J6 pin 2)

E-Stop (120 VAC) - J6 pin 3 (from 1100-1 TB1 pin 10)

Disables all 120V and 230V outputs from the 1330 when VMC is in E-Stop.

Drawbar and Arm Interlock

J6 pins 5 and 6 (from 1100-2 TB1 23 & 24) Disables arm and drawbar when spindle is on. Drawbar SSR on 1100-2 must be jumpered or arm and drawbar will not work.

Door Interlock (120 VAC) - J6 pin 7

(from 2000-1A J2 pin 3 or 1310-1C J1 pin 9)

Disables arm when doors are open. (If there is no 1310 or 2000 board, J6 pin 7 must be jumpered to J6 pin 8.)

Head Position Sensor- J11 (Hall sensor or magnetic reed switch) Disables arm movement (K9) if the Z-axis is not at tool change position. If no tool change position sensor is installed, then J11 pins 2 and 3 must be jumpered.

OutPuts**2 Motors:**

- Motor for turret - 3-phase, bi-directional (5 triacs) (Interlocked with E-Stop)
- Motor for arm - 3-phase, bi-directional (5 triacs) (Interlocked with E-Stop, doors, spindle, and head position)

3 Valves:

- Drawbar (interlocked with E-Stop, spindle, and head position)
- Tool Down (interlocked with Tool Up and E-Stop)
- Tool Up (interlocked with Tool Down and E-Stop)

Contactor supplying 230 V 3-phase to 1330 (interlocked with E-Stop and overcurrent)

LED Indicators:

Sensor Inputs (Green):

- Tool Count - On at each tool position, off between tool positions.
- Arm at Home - On when arm is in home (or idle) position.
- Arm at Spindle - On when the arm is at the spindle.
- Stopping - On when arm is at home or at the spindle.
- Drawbar - On when drawbar is down.
- Tool Down - On when tool bucket is down.
- Tool Up - On when tool bucket is up.
- ATC Fault (Red) - On when there is a tool change fault.
- Heartbeat (Green) - Blinks indicating CPU is alive and functioning.
- Overload (Yellow) - Indicates a motor overload is occurring (flashes at 50/60 Hz).
- (Turret overload ≥ 4 A, Arm overload ≥ 7.5 A)
- Overcurrent (Red) - On after there has been an overcurrent
- (Turret overcurrent ≥ 13 A, Arm overcurrent ≥ 30 A)
- Output Indicators (Yellow):
- Turret FWDOn when turret moving forward. (Turret CCW)
- Turret REVOOn when turret moving reverse. (Turret CW)
- Arm FWDOn when arm moving.
- Arm REVOOn when arm commanded in reverse by Dual Arm menu
- Drawbar On while drawbar solenoid is commanded on (K1)
- Tool Down On while tool down solenoid is commanded on (K2)
- Tool Up On while tool up solenoid is commanded on (K3)
- Contactor On while 3-phase contactor is commanded on (K4)

Currents:

Peak current of the turret motor measures 4-6 A. Continuous current of the turret motor measures 0.8-1.2 A.

Peak current of the arm motor measures at 8-13 A. Continuous current of the arm motor measures at 2-3 A. (Since the arm movement is limited, this continuous current is less than 1 second).

Current Sensing:

There are two different values of current sensed for each motor: "overload" (current larger than allowable continuous value) and "overcurrent" (current well beyond allowable peak value). Overload will occur when the motor stalls. Overcurrent would occur when there is a short circuit or motor windings short.

The overload signal is returned to the microcontroller which checks its duration and shuts down the motor if it lasts beyond normal startup current. The overcurrent signal shut down the triacs through hardware and is returned to the microcontroller with the overload signal. Overloads will occur whenever the motor is started because starting current is greater than locked rotor current. Therefore it is normal to see the Overload LED flash when the motor starts.

Functional Explanations:

For board to have 120V for the SSRs:

- VMC must not be in E-Stop (E-Stop relay (K5) passes 120V through CB1 to SSRs).
- CB1 must not be tripped.

For board to have 3-phase power:

- Board must have 120V power (see above).
- There must not be an overcurrent (D17 lit).
- Contactor SSR (K4) must be energized.

For board to have 3 phase power to Arm triacs:

- Board must have 120V power (see above).
- Board must have 3-phase power (see above).
- Spindle must not be on (and Drawbar relay on 1100-2 must be jumpered); this energizes the Drawbar Interlock relay (K7).
- If CE machine, 120V output from 2000 (J2 pin 3) or 1310 (J1 pin 9) board must go to J6 pin 7 (doors must be closed);
- If not CE, J6 pin 7 must be jumpered to J6 pin 3
- (CNC should not allow arm movement with doors open).
- Once all of the above conditions are met, Arm Power relay will be energized.

For drawbar to be energized:

- Board must have 120V power.
- Spindle must be off (Drawbar Interlock relay energized; this passes 120V power to Drawbar SSR and floats Drawbar enable to AND gate).
- Drawbar SSR must be energized.

For Tool Up or Tool Down solenoid to be energized:

- Board must have 120V power (see above).

- SSR for Tool Up or Tool Down must be energized.
- (Logic on the 1330 will disable Arm Up if Arm down is on and vice versa).

For Turret Fwd or Turret Rev to be active (turret in motion):

- Board must have 120V power (see above).
- Board must have 3-phase power (see above).
- (Spindle may be on. Turret motion with the spindle on is allowable but not arm motion.)
- Overcurrent latch must be reset by microcontroller.
- Turret Fwd or Turret Rev (not both) must be active (low).

For Arm Fwd or Arm Rev to be active (arm in motion):

- Board must have 120V power (see above).
- Board must have 3-phase power (see above).
- Spindle must be off (Drawbar Interlock relay energized; this pulls arm enable to OR gates low).
- Z-axis must be at tool change position (LED D20). If head is not at tool change position, K9 will not be energized which will disable K8. (If there is no head position sensor (J11) then J11 pins 2 and 3 must be jumpered. Shunt ELE-0088 is recommended for this.)
- If CE machine, 120V output from 2000 or 1310 board must go to J6 pin 7 (doors must be closed); if not CE, J6 pin 7 must be jumpered to J6 pin 3. (CNC should not allow arm movement with doors open).

Once all of the above conditions are met, the Arm Power relay will be energized:

- Overcurrent latch must be reset by microcontroller.
- Arm Fwd or Arm Rev (not both) must be active (low).

**Scheduled
Maintenance**

The maintenance schedule is based on machine usage of eight hours a day, five days a week.

Daily Maintenance

Perform the following daily:

- 1) Cleaning
 - a. Remove the chips and debris surrounding the proximity switch inducing block.
 - b. Remove the chips and debris that have accumulated on the inverted moving body of the tool pot.
 - c. Clear the tool changing mechanism of all debris before any operation.
- 2) Inspection:
 - a. Check the parts of the tool falling mechanism for damage and wear. Add grease to the sliding base of the tool falling mechanism and the pull rod.
 - b. Check the parts of the tool pots, tool discs, and snap rings for damage and tightness.

Weekly Maintenance

Perform the following weekly:

- 1) Greasing:
 - a. Grease the claws of the tool changing arm unit.
 - b. Grease the tip of the release pin of the tool changing unit.

Miscellaneous Maintenance

Perform the following as necessary:

- 1) Change the lubricant annually or as needed. The recommended lubricant is SAE 90-140. The Dual Arm Tool Changer uses approximately 5 liters (1.3 gallons).

50 Taper Dual Arm Tool Changer

Tool Changer Specifications

Type of Tool		CAT-50/BT-50
Number of Tools		32
Maximum Tool Diameter		
	All Pockets Full	Ø125mm (4.92in.)
	Adjacent Pockets Empty	Ø250 (9.85in.)
Maximum Tool Length	Maximum	400mm (15.75in.)
Tool Weight	Maximum	18kg. (40lb.)
Tool Magazine Drive Source		
	Motor Voltage	AC 220 V, 3 Phases
	Air Pressure	5~7kg/Cm (70-100 psi)

Sub-Assemblies

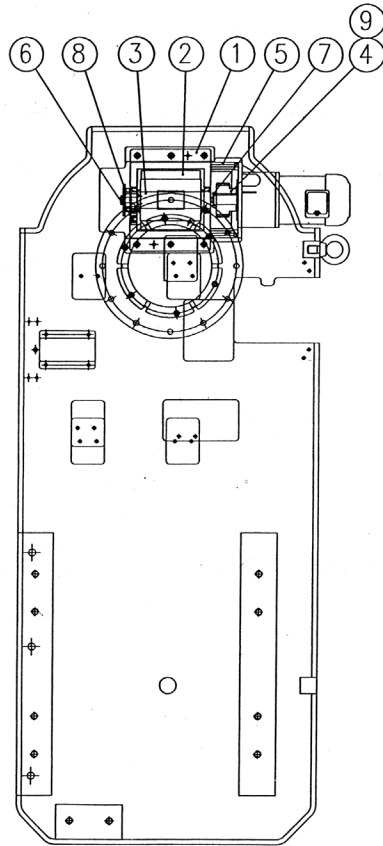

Figure 5-22 Index Mechanism

No.	Part Description
1	Cam Base
2	Cylindrical Cam
3	Driving Spindle
4	Gear
5	Motor Base
6	Proximity Switch Base
7	Gear's Locking Basket
8	Proximity Switch Block
9	Gear

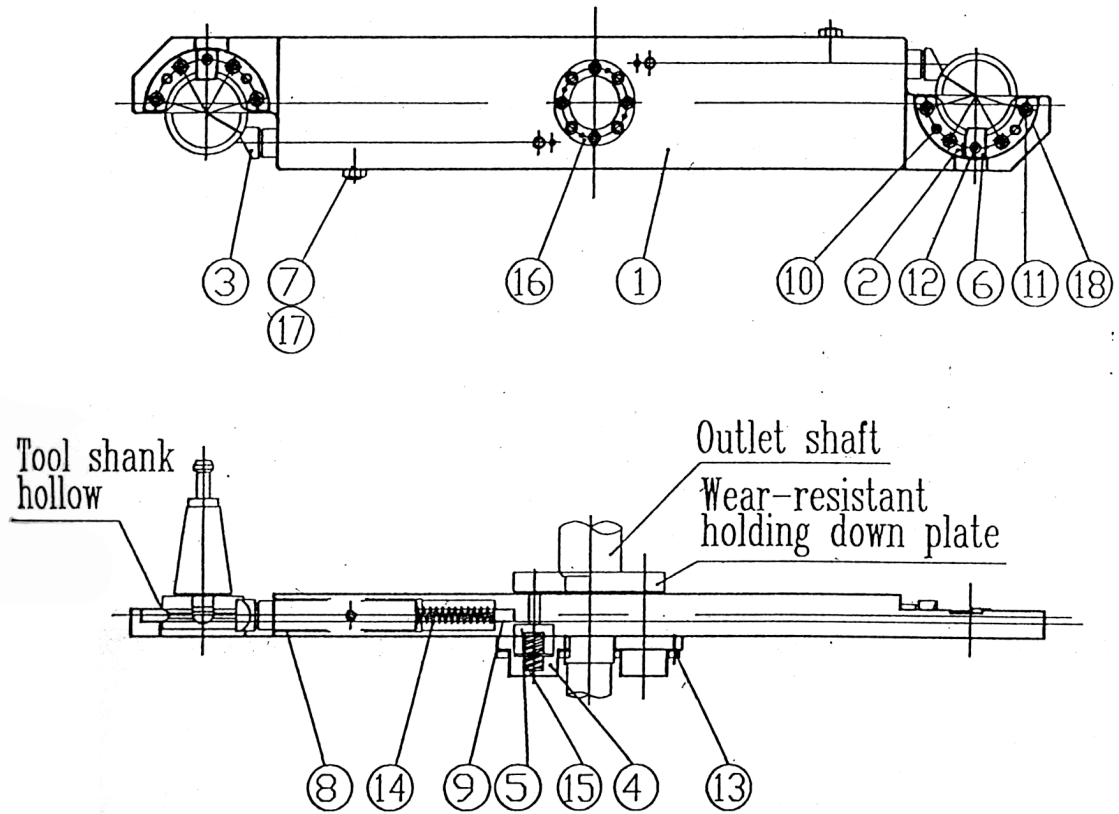

Figure 5-23 50 Taper Tool Arm

No.	Part Description	No.	Part Description
1	Tool Arm Body	12	Counter Sunk Screw
2	Gripper	13	Female Hexagon Bolt
3	Tool Holding Rod	14	Spring(2)
4	Spring Cover	15	Spring(1)
5	Fixing Rod	16	Locking Ring
6	Positioning Key	17	Hexagon Nut
7	Positioning Bolt	18	Catching Claw Pad
8	Self Lubricating Bearing		
9	Self Lubricating Bearing		
10	Pin		
11	Female Hexagon Bolt		

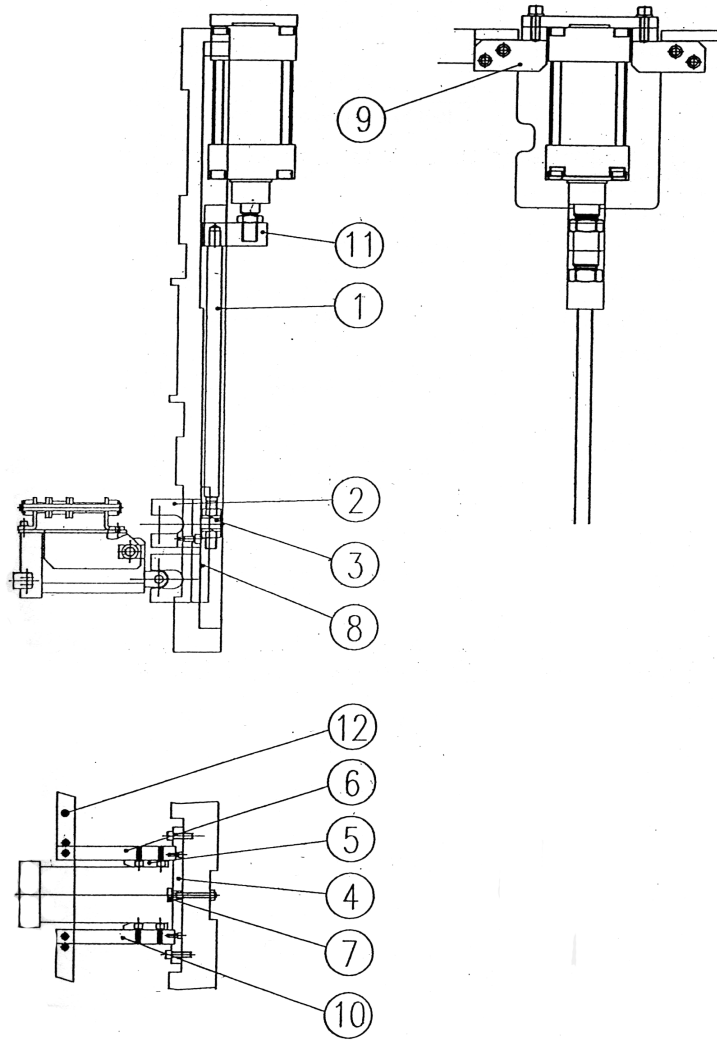

Figure 5-24 Tool Falling Mechanism

No.	Part Description	No.	Part Description
1	Tool Falling Pull Rod	9	Cylinder Base
2	Sliding Block	10	Positioning Slide Block
3	Sliding Block Cover Plate	11	Connecting Block
4	Positioning Block	12	R-Fixing Plate
5	Positioning Sliding Block (1)		
6	Positioning Sliding Block (2)		
7	Pot Fixing Base		
8	Positioning Block		

CONTROL ELEMENTS

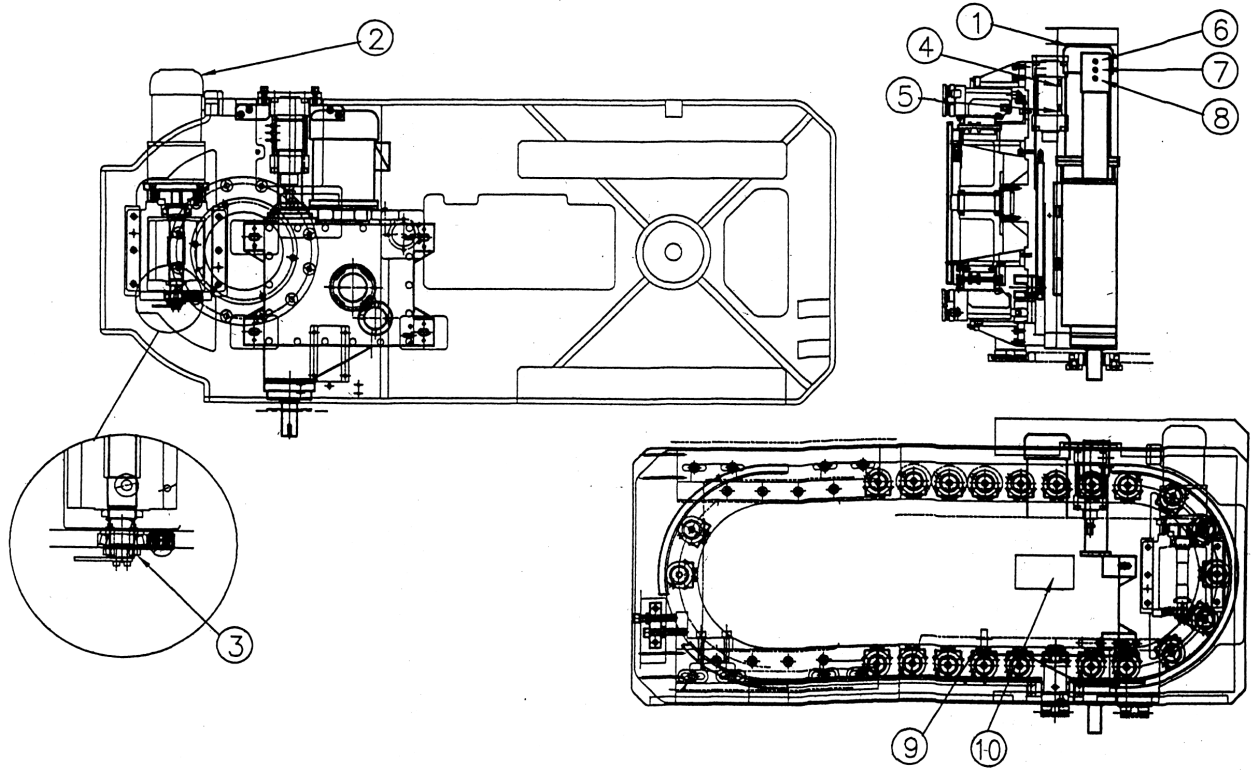

Figure 5-25 Control Elements

No.	Part Description
1	Tool Changing Mechanism Motor
2	Index Mechanism Motor
3	Proximity Switch 1
4	Reed Switch 2
5	Reed Switch 1
6	Proximity Switch 2
7	Proximity Switch 3
8	Proximity Switch 4
9	Proximity Switch 4
10	Control Box

- Installation**
- 1) Check if all the bolts and parts are affixed tightly (they might be loose during transportation). If not; fasten them tightly.
 - 2) Check if the automatic tool changer has any interference with the column of machining center or other area while connecting to the interface.
 - 3) Check voltage specification of motors, sensors and wiring condition to see if they are all compatible with the control system of the machining center.
 - 4) Insure that the conducting wire of control elements during installation is not damaged.
 - 5) Install the automatic tool changer with the machining center, adjusting the relative position between the tool arm and spindle.
 - a. When manually rotating the tool arm for the proper angle, put the wrench on the top of the tool changing mechanism motor shaft to rotate the arm.
 - b. While rotating the arm, pull rod of the motor brake must be released for smooth rotation.
 - c. Adjust the shaft of the arm and spindle in the vertical direction so that they are parallel.
 - 6) Connect each control element according to the diagrams with the relative points of the machining center.
 - 7) When programming the automatic tool changer, note the protection programming between each single action and refer to 'SEQUENCE OF ELECTRIC ACTIONS' and 'INSTALLATION NOTICE'.
 - 8) Check all the wiring and the relative connections to see if they are accurate before trial running.
 - 9) When performing the trial running, take single action in the beginning, then go for successive actions.
 - 10) If the trial running of single action is not smooth, stop running to check, in order to avoid any damage.
 - 11) If it is necessary, prolong the time between each related action.
 - 12) When performing the successive running, be careful not to miss any interlock protection programming between all the relative actions.

- Installation Notice** 1) Make the necessary interlock protection programming for all the relative connections. The following chart is for reference.

Relay Control	Tool Disk Rotation	Tool Falling	Tool Returning	Tool Changing Mechanism Action
Tool Disc Starting		Off	Off	Off
Reed switch of tool returning (protruding of cylinder)	On			
Reed switch of tool returning (protruding of cylinder)				On
Proximity switch of tool counting and positioning of tool disk		On	On	On
Relay of tool changing mechanism motor starting	Off	Off		
Proximity switch of origin of tool changing mechanism	On	On		

- 2) After the tool falling of the tool pot is completed, there must be little prolonged time (0.10.25 seconds) before the tool catching of arm. The purpose is to have sufficient air pressure inside the cylinder to avoid shaking of the tool pot while tool catching.
- 3) After the sensor of the tool unclamping or the tool clamping of the spindle claw is sensed, there could be some prolonged time if necessary. If the tool arm is proceeding the next action before the tool has been unclamped or clamped completely from spindle claw, tool might be forced to be pulled out or the tool might be falling.
- 4) Adjust the pressure of cylinder to be 5-7 kg/c m².

Troubleshooting

Symptom	Possible Reasons	Solution
Tool disk is not rotating while tool selecting	<ol style="list-style-type: none"> 1. Proximity switch of tool counting and positioning of tool disc is not sensed 2. Proximity switch is out of order 3. Index mechanism motor is out of order 4. Motor brake is out of order 5. Reed switch of tool returning (protruding of cylinder) is not at the proper position 	<ol style="list-style-type: none"> 1. Adjust the proximity switch to the proper position 2. Change a new proximity switch 3. Repair the motor or change a new one 4. Check the wiring or change its parts 5. Adjust it to the proper position
Tool disc does not stop at locating position	<ol style="list-style-type: none"> 1. Brake of index mechanism motor is not working 2. Distance between proximity switch of tool counting & positioning of tool disc and inducing block is too long 3. Proximity switch is out of order 	<ol style="list-style-type: none"> 1. Check if wiring of brake is correct or if its parts are out of order 2. Adjust the distance between proximity switch and inducing block to be closer 3. Change a new proximity switch
Tool disc keeps Rotating	<ol style="list-style-type: none"> 1. Distance between proximity switch of tool counting & positioning of tool disc and inducing block is too long 2. Proximity switch is out of order 	<ol style="list-style-type: none"> 1. Adjust the distance between proximity switch and inducing block to be closer 2. Change a new proximity switch
Fixing base of tool pot is deformed	Tool disc rotates while tool pot is falling	Change a new set of fixing base, and adjust, then put spring in
Tool disc is stuck while rotating	<ol style="list-style-type: none"> 1. "C" snap ring is loose, or parts of tool pot fixing base are falling apart 2. Cylinder works while tool disc is rotating, so tool pot is stuck at tool falling position 	<ol style="list-style-type: none"> 1. Disassemble the scattered fixing base and check each part if they are all workable of change a new set of fixing base 2. Check if the tool pot fixing base is deformed. Put sliding block of tool falling and roller back if they are falling apart

Symptom	Possible Reasons	Solution
Tool pot is shaking while tool returning or tool falling	<ol style="list-style-type: none"> 1. Sliding base of tool falling is not lubricated enough 2. Speed of cylinder is not even 	<ol style="list-style-type: none"> 1. Apply grease 2. Adjust intake pressure and speed adjusting device of cylinder
Tool pot is not at locating position while tool falling or tool returning	Blots of pull rod of tool falling are loose	Adjust bolts of pull rod of tool falling to be normal and tighten them
Cylinder is not acting	<ol style="list-style-type: none"> 1. Reed switch of tool falling (contracting of cylinder) is out of order 2. Reed switch of tool returning (protruding of cylinder) is out of order 3. Tool disc is not at locating position 4. No intake pressure in cylinder 	<ol style="list-style-type: none"> 1. Change a new reed switch 2. Change a new reed switch 3. Set tool disc to the locating position 4. Check if air resource has air and if solenoid valve is working
Arm is not rotating while tool changing	<ol style="list-style-type: none"> 1. Inducing block of origin of tool changing mechanism is not at the proper position 2. Proximity switch is out of order 3. Reed switch of tool falling (contracting of cylinder) is not at the proper position 	<ol style="list-style-type: none"> 1. Adjust it to the proper position 2. Change a new proximity switch 3. Adjust it to the proper position
Arm is not rotating after tool catching	<ol style="list-style-type: none"> 1. Inducing block of tool catching of tool changing mechanism is not at the proper position 2. Proximity switch is out of order 	<ol style="list-style-type: none"> 1. Adjust it to the proper position 2. Change a new proximity switch
Tool catching of arm is not accurate	The relative position between arm and spindle is not correct	<p>How to Adjust Arm:</p> <ol style="list-style-type: none"> 1. Pull the pull rod of clutch downwards. 2. Use hexagon handle to turn motor and make the arm rotate to the angle of tool catching. 3. Adjust the arm until the arm sticks to the caught tool. 4. Tighten the fixing bolt of the arm.

Symptom	Possible Reasons	Solution
Arm is not rotating after 180° tool changing	<ol style="list-style-type: none"> 1. Inducing block of tool catching of tool changing mechanism is not at the proper position 2. Proximity switch is out of order 	<ol style="list-style-type: none"> 1. Adjust it to the proper position 2. Change a new proximity switch
Arm stops at origin position but proximity switch of origin is not sensed	<ol style="list-style-type: none"> 1. Inducing block of origin is not at the proper position 2. Proximity switch is out of order 	<ol style="list-style-type: none"> 1. Adjust it to proper position 2. Change new proximity switch
Arm is supposed to stop at origin position but is not accurate	Inducing blocks are not at the proper position	Turn the 3 inducing blocks simultaneously to the proper angle
Motor is too hot	<ol style="list-style-type: none"> 1. Brake is not released 2. Brake is out of order 3. Commutator is out of order 	<ol style="list-style-type: none"> 1. Check commutator is with electricity or not 2. Repair the brake or change to a new one 3. Change a new commutator
Timing belt of tool changing mechanism is sliding from pulley	<ol style="list-style-type: none"> 1. The timing belt is too loose 2. The timing belt is worn 	<ol style="list-style-type: none"> 1. Adjust timing belt tight 2. Change a new timing belt

- Maintenance**
- 1) The lubricant inside the lubricant container of the tool changing mechanism should be changed after working for 2400 hours.

When the cam, rollers and the bevel gear are in use without lubricant, abnormal wear and fractures will occur. Appropriate quantity of lubricant should be a little more than half of the lubricant container.

- 2) Change of lubricant

The lubricant should be changed annually or when the lubricant becomes worse. Recommended lubricants viscosity: SAE 90140. Amount of lubricant: 5L.

- 3) Apply grease weekly
 - a. On the grippers of tool arm
 - b. On the tip of tool holding rod of tool arm
 - c. On the sliding block of tool falling, fixing base of pull rod of tool falling
- 4) Cleaning
 - a. Remove the chips around all the proximity switches and reed switches.
 - b. Remove the chips inside the tool pot.
 - c. The tool changing mechanism parts should be cleaned frequently so that the chips will not stick to it.
- 5) Check the tool falling mechanism parts regularly.
- 6) Check the parts of tool pots & tool disc and also check if "C" snap rings are tight regularly. If not, fasten them tightly or change new parts.

Dual Arm Tool Changer - Arm Installation

CAUTION!

The arm of the dual arm tool changer moves suddenly and with great force. Make sure that while performing the following procedure you and others are out of range of the arm.

Sending the Tool Changer Spindle to Home Position

- 7) Type DI and press ENTER.
- 8) Type DD and press ENTER.

- 9) In the Dual Arm Tool Changer Menu, select number 4 (Move Arm Reverse) or 3 (Move Arm Forward) to bring the tool changer spindle to its home position.

NOTE: While pressing 3 or 4, you will notice the tool changer spindle pause for a brief moment before it begins its tool changing procedure again. It is during that pause that the tool changer spindle is at its home position.

Inserting the Arm Assembly

NOTE: It is recommended that two people perform the following procedure.

- 1) Place the taper lock and arm assembly into the tool changer spindle. It is recommended that the side of the arm is parallel with side sheet metal wall of the tool changer. Make sure that there is a 3 to 4 mm space between the tool changer arm and the top of the tool changer spindle (see picture below).

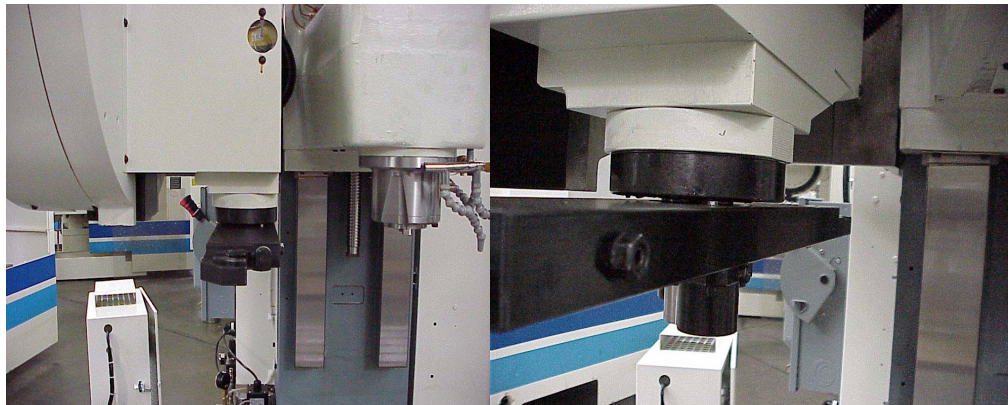

- 2) While holding the arm assembly, insert the installation tool (SVT-0149) and tighten with the 12mm bolt.



- 3) Snugly fasten (do not tighten!) the eight taper lock bolts at the bottom of the tool changer in a typical eight bolt crossing pattern.
- 4) Lower the tool pot to the tool change position.
- 5) Insert a tool holder into the spindle and the lowered tool pot.
- 6) Jog the Z axis to correct tool change position.
- 7) Lock the spindle with the M19 command.
- 8) Again enter the Dual Arm Tool Changer Menu and select number 4 (Move Arm Reverse) or 3 (Move Arm Forward) to slowly bring the arm into both tool holders.
- 9) Use your hands to push the tool changer arm into both tool holders making sure that both tool holders are gripped entirely by the tool changer arm.
- 10) Tighten the eight taper lock bolts at the bottom of the tool changer in a typical eight bolt crossing pattern.
- 11) Remove the installation tool (SVT-0149).

Dual Arm Tool Changer Alignment

- 1) Remove the dual arm head position sensor and replace with Jumper ELE-0088. (See pictures below).

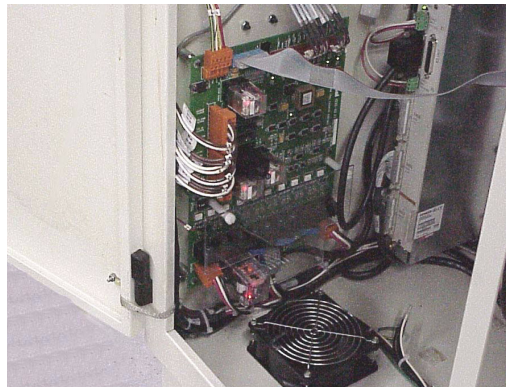

- 2) Lock the spindle with the M19 command.
- 3) Jog the Z axis up.

Entering the Dual Arm Tool Changer Menu

- 1) Type DI and press ENTER.
- 2) Type DD and press ENTER.

CAUTION!

The arm of the dual arm tool changer moves suddenly and with great force. Make sure that while performing the following procedure you and others are out of range of the arm.

- 3) In the Dual Arm Tool Changer Menu select number 4 (Move Arm Reverse) or 3 (Move Arm Forward) to bring the tool changer arm as close as possible to the spindle.
- 4) Place a tool in the arm of the tool changer.
- 5) Touch a flat surface of the tool with a .005 indicator and set to \emptyset . (See the picture below).

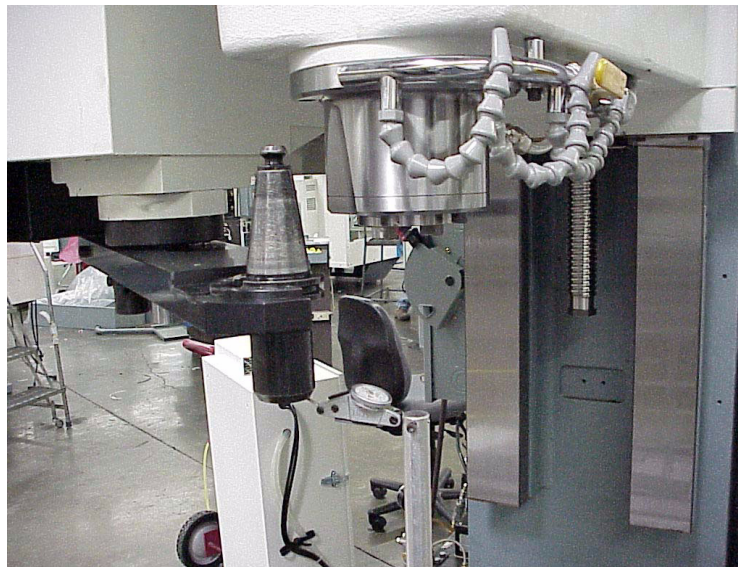

- 6) Carefully slide the indicator away from the tool, and remove the tool.
- 7) In the Dual Arm Tool Changer Menu select number 4 (Move Arm Reverse) or 3 (Move Arm Forward) to move the arm back to its standby position.
- 8) Place the tool in the spindle and lower the Z axis 3" approx.
- 9) Slide the indicator in, and place the needle in the same spot where the \emptyset was set in the arm.
- 10) Lower the Z axis until the indicator is \emptyset . (See the picture below).

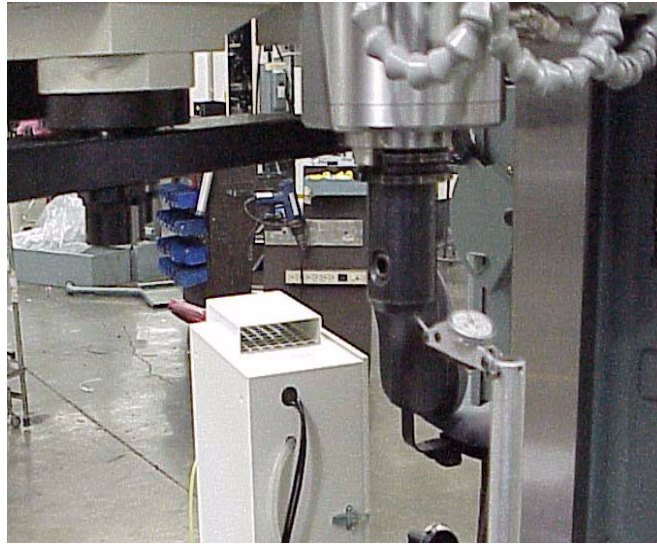

- 11) Carefully slide the indicator away and Cold Start the machine.
- 12) Slide the indicator back in, under the tool and adjust the Z axis until the indicator is \emptyset . Write or remember the distance traveled to reach \emptyset (example: -.994).
- 13) Press MANUAL.
- 14) Type SV, press ENTER.
- 15) Select Z.
- 16) Use the letter U or D to select [zero offset] \emptyset .
- 17) Enter the distance traveled to reach \emptyset (example: -994).
- 18) Press ENTER.
- 19) Press MANUAL.
- 20) Cold start the machine.
- 21) After the machine has finished the cold start procedure, verify with the indicator to make sure that it is \emptyset .
- 22) Remove the indicator.
- 23) Lower the Z axis 3.25".

24) Select a flat surface on the spindle and set the indicator to \emptyset . (see below).

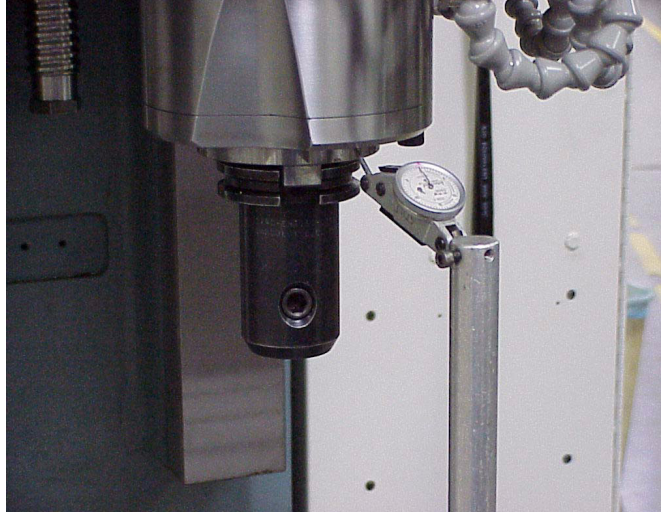

25) Carefully slide the indicator out of the way.

26) Type SV press ENTER.

27) Select Z.

28) Use the letter U or D to select [zero offset].

29) Enter \emptyset .

30) Press MANUAL.

31) Cold start the machine. (The Z axis should still be 3.25" down).

32) After the machine has finished the cold start procedure, carefully slide the indicator under the spindle and lower the Z axis until it reads \emptyset .

33) Write down or remember the distance traveled to reach \emptyset .

34) Type SV, and press ENTER.

35) Select "Z".

36) Use the letter "U" or "D" to select [zero offset].

37) Enter \emptyset .

38) Press MANUAL.

39) Cold start the machine.

40) Slide the indicator under the spindle to double check \emptyset .

**PCB-0213 Dual Arm
ATC Controller Card****Description and
Explanation of
Operation of PCB-
0213 (1330-0A)**

The 1330-0A is identical to the 1330-0 in terms of connections and operation with the following exceptions: an LED indicator has been added for the drawbar position sensor input, the overload sensing threshold for turret motor has been changed, and a spindle head position sensor has been added to interlock arm movement. This last change is the most significant; if the Z-axis is not at the tool change position, relays K9 and K8 will not allow the arm to move.

The 1330-0A is used on both Fadal and Siemens controls. However, the software is different for Siemens control from the Fadal control and is ordered separately from the PCB-0213.

Inputs 8-bit data port with strobe and ack for commands (bi-directional) - J4

6 sensors - J1 and J2:

Tool Count - proximity sensor, Namur PNP, active source

Home position - proximity sensor, Namur PNP, active source

Tool Change Position - proximity sensor, Namur PNP, active source

Stopping Position - proximity sensor, Namur PNP, active source

Drawbar down sensor - Hall Sensor, active low

Tool Down - reed sensor, NPN, normally open

Tool Up - reed sensor, NPN, normally open

(All sensor inputs except for drawbar can be configured for different sensors than those shown.)

All sensor inputs have LEDs indicating their status. These inputs cannot be checked with a volt meter because the sensors are current devices.

+5V, +12V, GND - J5

120 VAC (J6 pin 1)

RET (J6 pin 2)

E-Stop (120 VAC) - J6 pin 3 (from 1100-1 TB1 pin 10) Disables all 120V and 230V outputs from the 1330 when VMC is in E-Stop.

Drawbar and Arm Interlock - J6 pins 5 and 6 (from 1100-2 TB1 23 & 24) Disables arm and drawbar when spindle is on. Drawbar SSR on 1100-2 must be jumpered or arm and drawbar will not work.)

Door Interlock (120 VAC) - J6 pin 7 (from 2000-1A J2 pin 3 or 1310-1C J1 pin 9)

Disables arm when doors are open. (If there is no 1310 or 2000 board, J6 pin 7 must be jumpered to J6 pin 8.)

Head Position Sensor - J11 (Hall sensor or magnetic reed switch) Disables arm movement (K9) if the Z-axis is not at tool change position. If no tool change position sensor is installed, then J11 pins 2 and 3 must be jumpered.

Outputs

2 Motors

Motor for turret - 3-phase, bi-directional (5 triacs) (Interlocked with E-Stop)

Motor for arm - 3-phase, bi-directional (5 triacs) (Interlocked with E-Stop, doors, spindle, and head position)

3 Valves

Drawbar (interlocked with E-Stop, spindle, and head position)

Tool Down (interlocked with Tool Up and E-Stop)

Tool Up (interlocked with Tool Down and E-Stop)

Contactors supplying 230V 3-phase to 1330 (interlocked with E-Stop and overcurrent)

LED Indicators

Sensor Inputs (Green):

Tool Count - On at each tool position, off between tool positions.

Arm at Home - On when arm is in home (or idle) position.

Arm at Spindle - On when the arm is at the spindle.

Stopping - On when arm is at home or at the spindle.

Drawbar - On when drawbar is down.

Tool Down - On when tool bucket is down.

Tool Up - On when tool bucket is up.

ATC Fault (Red) - On when there is a tool change fault.

Heartbeat (Green) - Blinks indicating CPU is functioning.

Overload (Yellow) - Indicates a motor overload is occurring (flashes at 50/60 Hz).

(Turret overload ≥ 4 A, Arm overload ≥ 7.5 A)

Overcurrent (Red) - On after there has been an overcurrent.

(Turret overcurrent ≥ 13 A, Arm overcurrent ≥ 30 A)

Output Indicators (Yellow):

Turret FWD On when turret moving forward. (Turret CCW)

Turret REV On when turret moving reverse. (Turret CW)

Arm FWD On when arm moving.

Arm REV On when arm commanded in reverse by Dual Arm menu.

Drawbar On while drawbar solenoid is commanded on. (K1)

Tool Down On while tool down solenoid is commanded on. (K2)

Tool Up On while tool up solenoid is commanded on. (K3)

Contactors On while 3-phase contactor is commanded on. (K4)

Currents **Peak current** of the turret motor measures 4-6 A. Continuous current of the turret motor measures 0.8-1.2 A.

Peak current of the arm motor measures at 8-13 A. Continuous current of the arm motor measures at 2-3 A. (Since the arm movement is limited, this continuous current is less than 1 second.)

Current Sensing

There are two different values of current sensed for each motor: "overload" (current larger than allowable continuous value) and "overcurrent" (current well beyond allowable peak value). Overload will occur when the motor stalls. Overcurrent would occur when there is a short circuit or motor windings short.

The overload signal is returned to the microcontroller which checks its duration and shuts down the motor if it lasts beyond normal startup current. The overcurrent signal shuts down the triacs through hardware and is returned to the microcontroller with the overload signal. Overloads will occur whenever the motor is started because starting current is greater than locked rotor current. Therefore it is normal to see the Overload LED flash when the motor starts.

Functional Explanations

For board to have 120V for the SSR's:

- VMC must not be in E-Stop (E-Stop relay (K5) passes 120V thru CB1 to SSR's).
- CB1 must not be tripped.

For board to have 3-phase power:

- Board must have 120V power (see above).
- There must not be an overcurrent (D17 lit).
- Contactor SSR (K4) must be energized.

For board to have 3 phase power to Arm triacs:

- Board must have 120V power (see above).
- Board must have 3-phase power (see above).
- Spindle must not be on (and Drawbar relay on 1100-2 must be jumpered); this energizes the Drawbar Interlock relay (K7).
- If CE machine, 120V output from 2000 (J2 pin 3) or 1310 (J1 pin 9) board must go to J6 pin 7 (doors must be closed); if not CE, J6 pin 7 must be jumpered to J6 pin 3.
- CNC should not allow arm movement with doors open.

If all the above is true the Arm Power relay will be energized.

For drawbar to be energized:

- Board must have 120V power.

- Spindle must be off (Drawbar Interlock relay energized; this passes 120V power to Drawbar SSR and floats Drawbar enable to AND gate).
- Drawbar SSR must be energized.

For Tool Up or Tool Down solenoid to be energized:

- Board must have 120V power (see above).
- SSR for Tool Up or Tool Down must be energized.
- Logic on the 1330 will disable Arm Up if Arm down is on and vice versa.

For Turret Fwd or Turret Rev to be active (turret in motion):

- Board must have 120V power (see above).
- Board must have 3-phase power (see above).

(Spindle may be on. Turret motion with the spindle on is allowable but not arm motion.)

- Overcurrent latch must be reset by microcontroller.
- Turret Fwd or Turret Rev (not both) must be active (low).

For Arm Fwd or Arm Rev to be active (arm in motion):

- Board must have 120V power (see above).
- Board must have 3-phase power (see above).
- Spindle must be off (Drawbar Interlock relay energized; this pulls arm enable to OR gates low).
- Z-axis must be at tool change position (LED D20). If head is not at tool change position, K9 will not be energized which will disable K8. (If there is no head position sensor (J11) then J11 pins 2 and 3 must be jumpered. Shunt ELE-0088 is recommended for this.)
- If CE machine, 120V output from 2000 or 1310 board must go to J6 pin 7 (doors must be closed);
- If not CE, J6 pin 7 must be jumpered to J6 pin 3. (CNC should not allow arm movement with doors open).

If all the above is true the Arm Power relay will be energized.

Overcurrent latch must be reset by microcontroller.

Arm Fwd or Arm Rev (not both) must be active (low).

**Sequence of Dual
Arm-ATC Operation
When Used With The
Fadal Control**

Feedback Tool Up sensor (Magnetic reed switch mounted at Bottom of Air Cylinder- normally open – “Tool Up” LED)

Tool Down sensor (Magnetic reed switch mounted at Top of Air Cylinder- normally open -“Tool Down” LED)

Above sensors have a LED mounted into the sensor and 1330-0 card that is lit when switch is closed.

Arm Stop (Proximity current sensor #1 mounted at Top on Arm – “Stopping Sensor” LED)

Arm Tool(Proximity current sensor #2 mounted at Center on Arm – “Arm at Spindle” LED)

Arm Home(Proximity current sensor #3 mounted at Bottom on Arm – “Arm at Home” LED)

Tool Count sensor (Proximity current sensor mounted under Turret Motor – “Tool Count” LED)

Drawbar sensor (Hall Effect sensor mounted under Drawbar Cylinder – “Drawbar” LED)

Above sensors have a LED mounted on the 1330-0 card that is lit when switch is closed.

Part Numbers Magnetic Reed Switches ELE-1186
Proximity Current Sensors ELE-1185
Hall Effect Sensors ELE-0145

#	Error Message	Description
1	CAROUSEL SOLENOID FAILURE (OR SENSOR)	Tool Count Sensor was not seen.
2	DRAWBAR SOLENOID FAILURE (OR NO AIR)	The Drawbar Cylinder could not be moved down to extract tool. Check Air Supply. Check Tool.
3	DRAWBAR SENSOR FAILURE	The Drawbar Cylinder piston could not return home.
4	ATC ARM IS NOT IN HOME POSITION	The ATC Arm did not arrive at ATC Home.
5	ATC BUCKET UP SOLENOID/SENSOR FAILURE	The ATC Bucket Cylinder did not arrive at BOTTOM (Bucket move UP).
6	ATC BUCKET DOWN SOLENOID/SENSOR FAILURE	The ATC Bucket Cylinder did not arrive at TOP (Bucket move DOWN).
7	ATC ARM SOLENOID SENSOR/HOME SENSOR FAILURE	The ATC Arm could not move away from HOME.
8	ATC TOOL ARM OBSTRUCTED	The ATC Arm did not arrive at Spindle.
9	ATC TOOL SENSOR FAILURE	The ATC Arm TOOL Sensor was not seen.
10	ATC TOOL CLAMPING FAILURE	The ATC Arm could not move down from Spindle.
11	ATC TOOL UNCLAMPING FAILURE	The ATC Arm could not leave Tool Holders.
12	ATC INTERLOCK IS ON	
13	ATC COMMUNICATION ERROR WITH 1330-CARD	1400-5 cannot communicate with the 1330.
14	ATC AMBIGUOUS BUCKET POSITION	ATC Bucket is neither UP nor DOWN. Neither reed switch is seen.
15	ATC AMBIGUOUS TURRET POSITION	ATC Turret is in-between Buckets. Turret (Tool Count) Sensor is not seen.

DA-ATC Tool Change Cycle—Fadal Control

- 1) Initiate Turret Rotate cycle Tx, where x is the Tool number to be moved to Arm Ready position.
- 2) Begin a new one second timer to initiate “Bucket UP” cycle, and verify that the Bucket is UP.
 - a. Enable 1330/K3 to power Air Valve to move Bucket UP.
 - b. If Air Cylinder bottom reed switch is CLOSED and the top reed switch is OPEN, then stop the timer. LED’s green “Tool Up” and yellow “Tool Up” are lit. Proceed to step 3.
 - c. If timer times out, the Bucket did not move up, and if bottom reed switch is OPEN and top reed switch is CLOSED, then get message #5—ATC BUCKET UP SOLENOID/SENSOR FAILURE. Halt system.
 - d. Or, if timer times out, the Bucket did not move up, and if top reed switch is OPEN and bottom reed switch is OPEN, then get message #14—AMBIGUOUS BUCKET POSITION. Halt system.

- 3) Begin a new one second timer to rotate Turret.
 - a. Enable 1330/K4 to CLOSE 3-Phase Contactor.
 - b. Turret motor rotates and TOOL COUNT sensor mounted below Turret Motor reports that Turret is away from home position, and TOOL COUNT LED goes out. LED's yellow "Contactor", green "Stopping Sensor" and "Arm at Home" are lit, TOOL COUNT is unlit.
 - c. If TOOL COUNT sensor is CLOSED again, then Turret has arrived at new tool, stop the timer. Proceed to step 4.
 - d. If timer times out, Turret Motor could not rotate, then get message #15—AMBIGUOUS TURRET POSITION. Halt system.
- 4) Repeat step 3, as Turret Motor rotates, 1330 counts impulses from TOOL COUNT sensor, until correct Tool is in position.
- 5) When correct Tool is in position, and TOOL COUNT sensor is CLOSED, disable 1330/K4 to open Contactor and stop Turret Motor.
- 6) Initiate Tool Change -- M6
- 7) Spindle OFF (M5). Orient Spindle (M19). Check for Orient Switch feedback.
 - a. If feedback received from Spindle Orientation Hall Effect switch, then Spindle is Oriented, STOP Spindle. K7 and K9, K3 and K4 OFF.
- 8) Control sends signal to 1330 card to begin Tool Change Cycle. 1330 card sends "Busy" signal to control.
- 9) Begin a new one second timer to initiate "Bucket DOWN" cycle.
 - a. Enable 1330/K2 to power Air Valve to move Bucket DOWN.
 - b. If Air Cylinder bottom reed switch is OPEN and the top reed switch is CLOSED, then stop the timer. LED's green "Tool Down" and yellow "Tool Down" are lit. Proceed to 10.
 - c. If timer times out, the Bucket did not move down, and if bottom reed switch is CLOSED and top reed switch is OPEN, then get message #6—ATC BUCKET DOWN SOLENOID/SENSOR FAILURE. Halt system.
 - d. Or, if timer times out, the Bucket did not move down, and if top reed switch is OPEN and bottom reed switch is OPEN, then get message #14—AMBIGUOUS BUCKET POSITION. Halt system.
- 10) Begin a new one second timer for "Arm to Spindle" cycle, and activate Triacs for Arm Motor to move.
 - a. Enable 1330/K4 relay to CLOSE 3-phase contactor.

- b. Stop the timer as soon as the Arm moves away from its home position, and the ARM STOP and ARM HOME sensors report that Arm is away. This verifies that the ARM STOP and ARM HOME signals are working properly. LED's yellow "Contactor" is lit; green "Stopping Sensor" and "Arm at Home" are NOT lit. Then proceed to step 11.
 - c. If the timer times out, and therefore the arm has not moved from the ARM HOME position, then get message #7, ATC ARM SOLENOID SENSOR/HOME SENSOR FAILURE. Halt system. Check Overload LED on 1330, Arm Motor Drive Belt, Contactor, move Arm manually by turning top of Arm Motor shaft—checking for resistance, check for dragging brake in Arm Motor, 1330/CB1 Circuit Breaker and fuses ahead of Contactor.
- 11) Begin a new one-second timer to initiate "Arm Approaching Spindle/ Bucket" cycle.
 - a. As soon as the ARM STOP and ARM TOOL signals are seen, stop the timer, disable 1330/K4 relay to disconnect Contactor to power OFF Arm Motor. LED's yellow "Contactor", green "Stopping Sensor" and "Arm at Spindle" are lit. Proceed to step 12.
 - b. If the timer times out, the arm has not arrived at Spindle and Turret Bucket. Get message # 8—ATC TOOL ARM OBSTRUCTED or if ARM STOP sensor was seen and ARM TOOL was not, get # 9--ATC TOOL SENSOR FAILURE. Halt system. Check Overload LED on 1330, Arm Motor Drive Belt, Contactor, move Arm manually by turning top of Arm Motor shaft—checking for resistance, check for dragging brake in Arm Motor, 1330/CB1 Circuit Breaker and fuses ahead of Contactor.
- 12) Begin a new one-second timer to initiate "Drawbar Down" cycle.
 - a. Enable the 1330/K1 relay to power Air Solenoid to Drawbar Cylinder.
 - b. As soon as Drawbar Cylinder Hall Effects switch is seen, stop the timer. LED's yellow "Drawbar", green "Stopping Sensor", "Drawbar" and "Arm at Spindle" are lit; yellow "Contactor" is NOT lit. Proceed to step 13.
 - c. If timer times out, then Tool could not be extracted from Spindle. Get message #2—DRAWBAR SOLENOID FAILURE (OR NO AIR). Halt system. Check Drawbar Cylinder Hall Effects switch and its adjustment, air supply, check for broken Drawbar Cylinder piston, Drawbar Cylinder leaks, Drawbar/Belleville spring problems, and Tool Holder/Pull Stud problems.
- 13) Begin a new one second timer to initiate "Arm DOWN" cycle.
 - a. Enable 1330/K4 relay to CLOSE 3-phase contactor.

- b. Stop the timer as soon as the Arm moves away from its Spindle position, and the ARM STOP and ARM TOOL sensors report that Arm is away. This verifies that the ARM STOP and ARM TOOL signals are working properly. Then rotate Arm 180 degrees. LED's yellow "Contactor" is lit, green "Stopping Sensor" and "Arm at Spindle" are NOT lit. Proceed to step 14.
 - c. If the timer times out, and therefore the arm has not moved from the ARM TOOL position, then get message #10, ATC TOOL CLAMPING FAILURE. Halt system. Check Overload LED on 1330, Arm Motor Drive Belt, Contactor, move Arm manually by turning top of Arm Motor shaft—checking for resistance, check for dragging brake in Arm Motor, 1330/CB1Circuit Breaker and fuses ahead of Contactor.
- 14) Begin a new one-second timer to re-initiate "Arm Approaching Spindle/ Bucket" cycle.
- a. As soon as the ARM STOP and ARM TOOL signals are seen, stop the timer, disable 1330/K4 relay to disconnect Contactor to power OFF Arm Motor. LED's yellow "Contactor", green "Stopping Sensor" and "Arm at Spindle" are lit. Proceed to step 15.
 - b. If the timer times out, the arm has not arrived at Spindle and Turret Bucket. Get message # 8—ATC TOOL ARM OBSTRUCTED or if ARM STOP sensor was seen and ARM TOOL was not, get # 9--ATC TOOL SENSOR FAILURE. Halt system. Check Overload LED on 1330, Arm Motor Drive Belt, Contactor, move Arm manually by turning top of Arm Motor shaft—checking for resistance, check for dragging brake in Arm Motor, and fuses ahead of Contactor.
- 15) Begin a new one second timer for "Clamp Tool" cycle.
- a. Disable 1330/K1 relay to stop Air Valve to Drawbar Cylinder.
 - b. If Drawbar Hall Effect Switch signal is OFF, then Tool is clamped. Stop the timer. LED's "Stopping Sensor", and "Arm at Spindle" are lit; yellow "Contactor" and "Drawbar", green "Drawbar" are NOT lit. Proceed to step 16.
 - c. If the timer times out, tool is NOT clamped. Get message #3—DRAWBAR SENSOR FAILURE. Halt system. This error message is incorrect. Check for fluid buildup in Drawbar Cylinder, broken return spring, mis-adjusted Hall Effect Switch.
- 16) Begin a new one second timer for the "Arm Return to Home" cycle.
- a. Enable 1330/K4 relay to CLOSE 3-phase contactor.
 - b. Stop the timer as soon as the Arm moves away from its Spindle position, and the ARM STOP and ARM TOOL sensors report that Arm is away. This verifies that the ARM STOP and ARM TOOL signals are work-

- ing properly. Then rotate arm to ATC HOME position. LED's yellow "Contactor" is lit, green "Stopping Sensor" and "Arm at Spindle" are NOT lit. Proceed to step 17.
- c. If the timer times out, and therefore the arm has not moved from the ARM TOOL position, then get message #11—ATC TOOL UNCLAMPING FAILURE. Halt system. Check Overload LED on 1330, Arm Motor Drive Belt, Contactor, move Arm manually by turning top of Arm Motor shaft—checking for resistance, check for dragging brake in Arm Motor, 1330/CB1 Circuit Breaker and fuses ahead of Contactor.
- 17) Begin a new one-second timer to initiate "Arm Approaching ATC Home" cycle.
- a. As soon as the ARM STOP and ARM HOME signals are seen, stop the timer, disable 1330/K4 relay to disconnect Contactor to power OFF Arm Motor. Disable Triacs to Arm Motor. LED's yellow "Contactor" is NOT lit; green "Stopping Sensor" and "Arm at Home" are lit. Proceed to 18.
 - b. If the timer times out, the arm has not arrived at Spindle and Turret Bucket. Get message # 8—ATC TOOL ARM OBSTRUCTED. Halt system. Check Overload LED on 1330, Arm Motor Drive Belt, Contactor, move Arm manually by turning top of Arm Motor shaft—checking for resistance, check for dragging brake in Arm Motor, and fuses ahead of Contactor. This page intentionally left blank.
- 18) Begin a new one second timer to initiate "Bucket UP" cycle.
- a. Enable 1330/K3 to power Air Valve to move Bucket UP.
 - b. If Air Cylinder bottom reed switch is CLOSED and the top reed switch is OPEN, then stop the timer. LED's green "Tool Up" and yellow "Tool Up" are lit. Proceed to step 19.
 - c. If timer times out, the Bucket did not move up, and if bottom reed switch is OPEN and top reed switch is CLOSED, then get message #5—ATC BUCKET UP SOLENOID/SENSOR FAILURE. Halt system.
 - d. Or, if timer times out, the Bucket did not move up, and if top reed switch is OPEN and bottom reed switch is OPEN, then get message #14—AMBIGUOUS BUCKET POSITION. Halt system.
- 19) Tool change cycle is completed. Stop "Busy" signal to control. Resume main program.

Changing tools on a TRM

The TRM has no automatic tool changer. Switching tools on the TRM must be done manually.

Warning

Please take all the precautions necessary to ensure your safety and the safety of others while switching a tool.

Releasing a tool

- 1) Make sure the spindle is at a complete stop and ready for a tool change.
- 2) Firmly hold the tool in the spindle.
- 3) Press the tool in/out button on the side of the head

Inserting a tool

- 1) Make sure the spindle is at a complete stop and ready for a tool change.
- 2) Firmly insert the tool in the spindle.
- 3) Press the tool in/out button on the side of the head.

Note: Make sure the tool is completely and correctly inserted before releasing the tool.

- 4) Release the tool in/out button.



50 Taper Pull Stud Specs (CAT/BT)

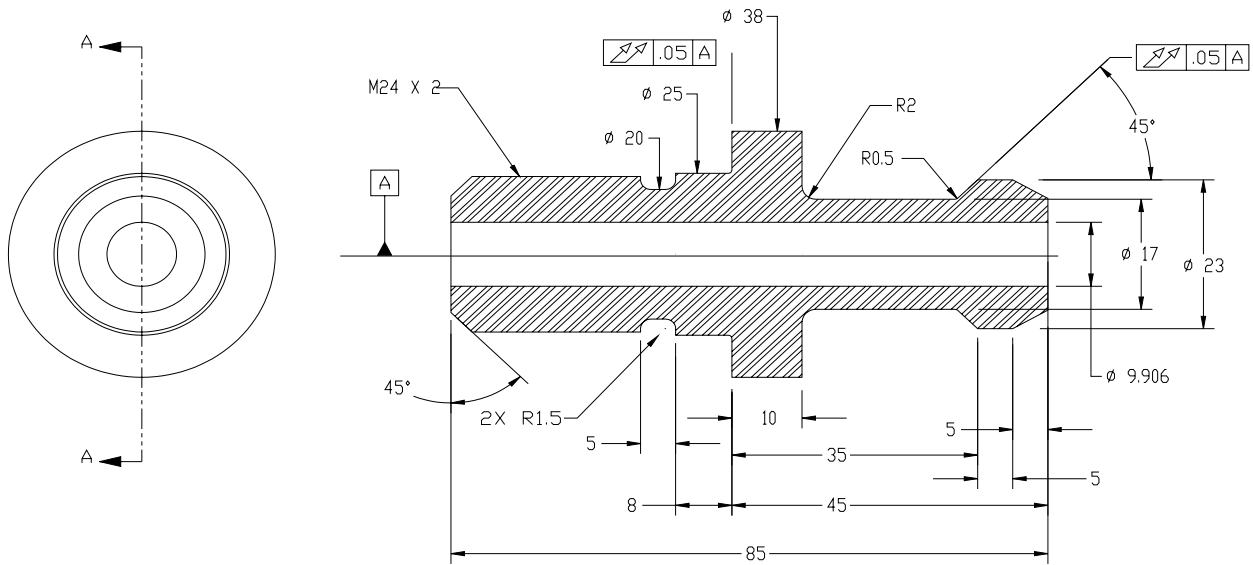

SECTION A-A

TOL-0590

KNOB, TOOL RETENTION,
50 TAPER BT, 45°

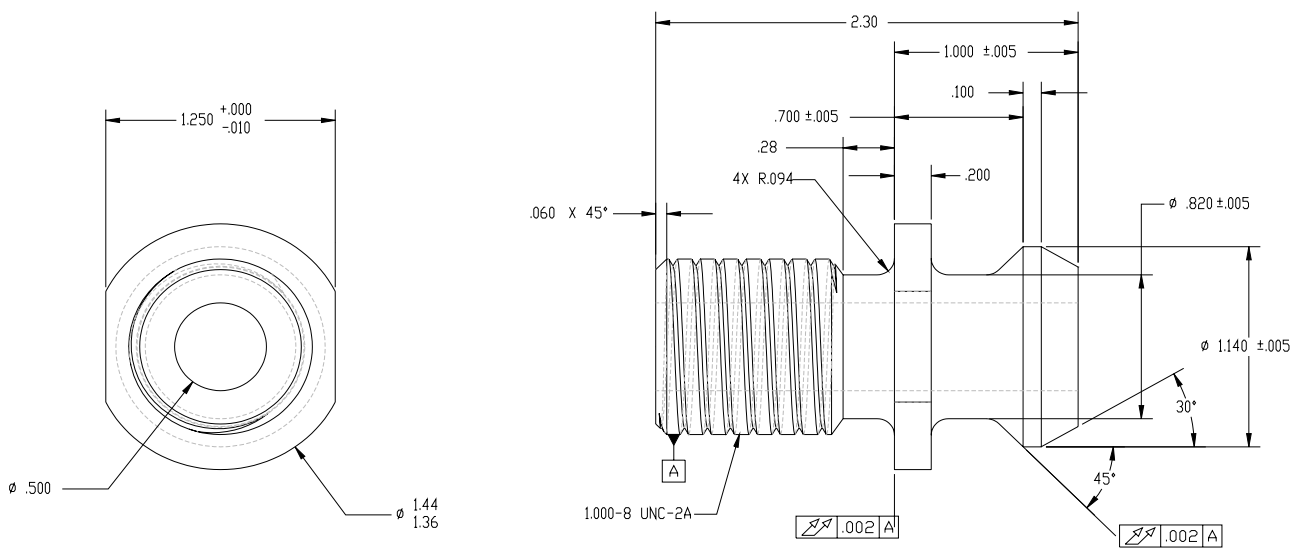

TOL-0591

PULL STUD, 50 TAPER, CAT